



EX3

TECHNOLOGY

SAFE · PRECISE · CERTIFIED

CHAIN HOIST

CONTROLLER

LOAD CELL



The brand name **EXE**[®] identifies a range of products designed for the entertainment & exhibition markets, offering a range of equipment engineered to safely manoeuvre stage equipment, scenery, video walls & other related structures...before, during and after your performance.

ALL IN ONE is designed as a fully integrated system including 'smart' hoists and intelligent controllers, offering plug and play devices. It is the integration between equipment designed to operate as a "single" stage machine.

Managing increasingly complex events, led us to imagine a world where our most advanced series and third-party products interacts with each other. It's a unique and ambitious project, that we called **ONE FOR ALL**: it's the open source system capable of interaction with third-party producers. A decisive step forward for the interaction of various technologies within the same event.



EX3 250 kg
RISE ■ D8 Plus

CHAIN HOIST

01

EX3 **RISE**

ELECTRIC CHAIN HOIST

DB+ 250kg	10
DB+ 500kg	12
DB+ 1000kg	14
DB+ 2000kg 2 REEVES	16
DB+ 1600kg	18
DB+ 2000kg 1 REEVE	20
DB+ 2500kg	22
250kg - 500kg SINGLE PHASE	24-25

ELECTRIC CHAIN HOIST ACCESSORIES

FLIGHT CASE	28-29
CHAIN BAG / RAIN COVER	30-31
CHAIN	32
CHAIN SLIDER / TOURING SLIDER	33
HOOK	34
UPGRADES	35

02

EX3 **HCB**

MANUAL CHAIN HOIST

HAND CHAIN BLOCK	36-37
------------------	-------

03

EX3 **IBEAM**

IBEAM TROLLEY

IBEAM	38-39
-------	-------

CONTROLLER

04

EX3 **DRIVE**

SELECTABLE CONTROLLER

DH1 / DH2	42-43
DB4 / DB4-LV	44-45
DB8 / DB8-LV	46-47
DL4 / DL4-LV	48-49
DL6	50
DL8 / DL8-LV	52-53
DL8H	54
DL16 / DL16-LV	56-57
DL24 / DL24-LV	58-59
DW8	60
DC4 / DC8	62-63
DC4 SP	64
XDRHG / XDRHGR	66
XDRHGC	67
XDRH4C / XDRH8C	68-69
XDRH16C / XDRH24C	70-71
XDSP2-LV / XDRH1C-LV	72
COMPATIBILITY CHART	73

05

EX3 **SENSE**

EXE TOUCH CONTROLLER

DL85	76
DLRH	78

LOAD CELL

06

EX3 **CELL**

WIRED LOAD CELL

LC-PRO COMPONENTS	81
LC-PRO CELL BOOSTER	82
LC-PRO CONFIGURATION	83
LC-PRO COMPATIBILITY CHART	84
LC-NLP COMPONENTS	85
LC-NLP32	88
LC-NLP CONFIGURATION	89
LC-PRO COMPATIBILITY CHART	90
LC-HKT	91
LC-HKT CELL BOOSTER	92
LC-HKT CONFIGURATION	93
LC-HKT COMPATIBILITY CHART	94



EXE TECHNOLOGY

MILESTONES



DST40



LC-PRO
CONFIGURATION



VARIABLE SPEED

EXE
RISE

EXE
DRIVE

EXE
RISE

2013

2014

2014

2015

2016

2017

EXE
DST

EXE
CELL

EXE
VARIO

SMALL AND
LARGE FRAME

DL & DB
PRODUCTS

WINNER OF THE
plasa 2015
AWARDS FOR INNOVATION

MEDIUM
FRAME





EX3
DST



EXTRA LARGE FRAME

EX3
DRIVE



MEDIUM FRAME COMPACT



ALL IN ONE SOLUTIONS

2018

2019

2020

2021

2022



EX3
RISE



DST52
DST66

EX3
RISE



WIRELESS CONTROLLER



ONE FOR ALL SOLUTIONS

2018

2019

2020

2021

2022



EXE RISE
CHAIN HOIST

**FIXED SPEED, PERFORMANCE
ORIENTED, MADE IN ITALY**



Fixed speed EXE Rise chain hoists have been specifically designed to satisfy the demanding needs and requests of the entertainment and touring market. Years of research and development have contributed to an extremely performance-oriented, precise and safe range of hoists that see customer trust increasing exponentially all over the world.

The electrical-mechanical features and high quality components of the hoist body are made in Italy, making EXE Rise chain hoists unique and unmatched on the international market.















Corrosion resistant aluminium alloy frames, non-reflective matte finish, housing a 5 pocket load wheel, complete double-brake units, and a clutch positioned outside of the load path. High quality D-A-T, case hardened steel chain either zinc plated, or black phosphated. Alloy steel swivel hooks with spring-loaded latches and the working load limit boldly marked at the chain hook.

All EXE Rise chain hoists are DB plus with a safety factor of 8-to-1 and can be ordered with either direct or low voltage control. Compatibility with all EXE Drive motor controllers, and the possibility of equipping them with an encoder, limit switch and load cell, allow EXE Rise chain hoists to meet all of our customers needs.

01

EXE RISE

OVERVIEW

		MEDIUM FRAME COMPACT	MEDIUM FRAME	LARGE FRAME		EXTRA LARGE FRAME COMPACT	EXTRA LARGE FRAME	
		D8+ 250kg/551lbs 1 REEVE	D8+ 500kg/1102lbs 1 REEVE	D8+ 1000kg/2205lbs 1 REEVE	D8+ 2000kg/4409lbs 2 REEVES	D8+ 1600kg/3527lbs 1 REEVE	D8+ 2000kg/4409lbs 1 REEVE	D8+ 2500kg/5512lbs 1 REEVE
FIXED SPEED	DIRECT CONTROL							
	LOW VOLTAGE CONTROL							

CHAIN HOIST

CLASSIFICATION

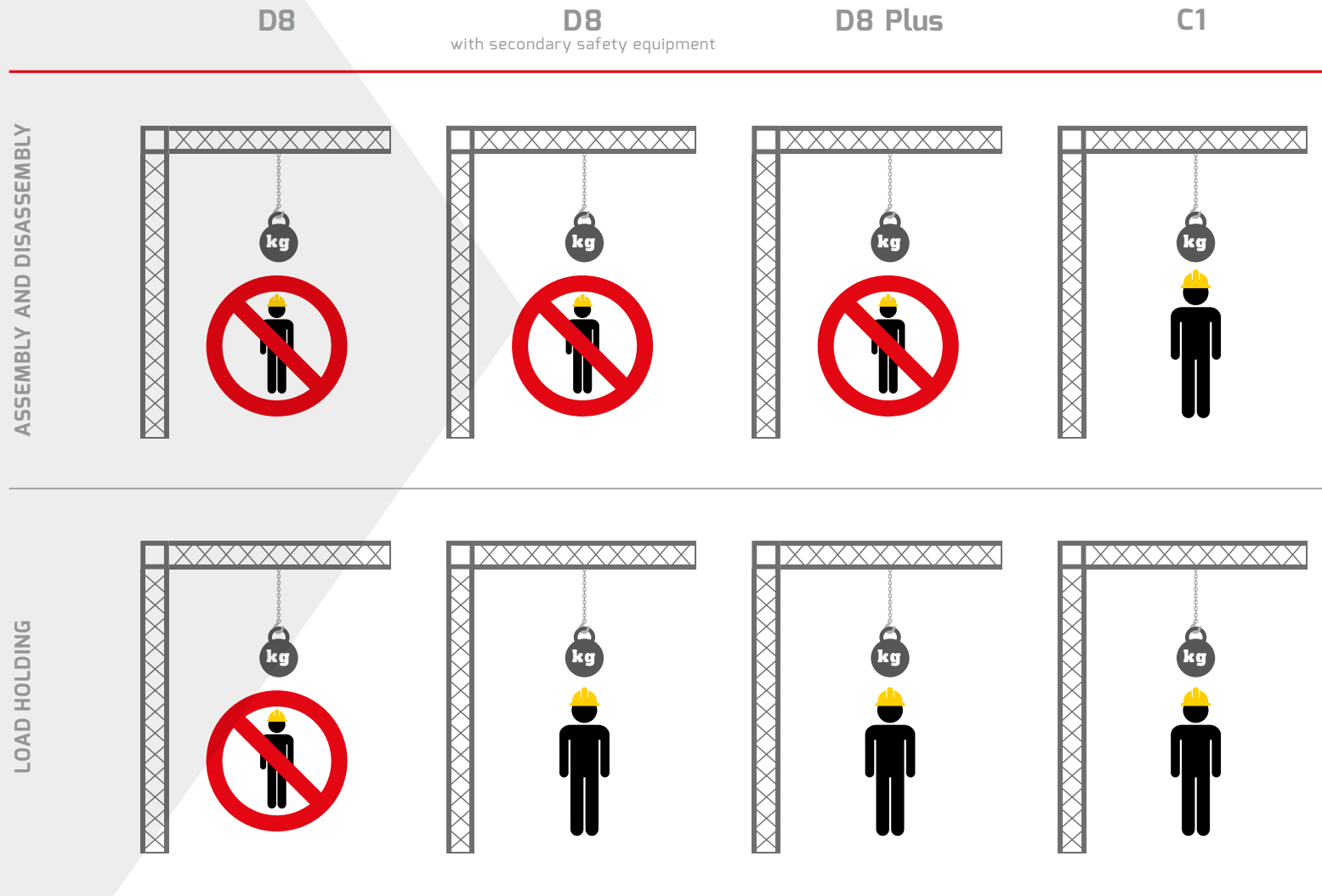

CHAIN HOIST

MECHANISM CLASSIFICATION

VERTICAL MOVEMENTS

ISO 4301	FEM 9.511	DUTY FACTOR OF MOTOR	MINUTES PER HOUR <i>Uniformly Distributed Work Period</i>	STARTS PER HOUR	HOUR PER DAY	HOUR / 10 YEARS Bearing Time
M1	1Dm	15%	9	90	≤ 0,25	400
M2	1Cm	20%	12	120	≤ 0,5	800
M3	1Bm	25%	15	150	≤ 1	1600
M4	1Am	30%	18	180	≤ 2	3200
M5	2m	40%	24	240	≤ 4	6300
M6	3m	50%	30	300	≤ 8	12500

RATE OF LOADING	Average time of supposed daily operation T_m (hour)		to 0.25	from 0.25 to 0.5	from 0.5 to 1	from 1 to 2	from 2 to 4	from 4 to 8	from 8 to 16
			to 400	to 800	to 1600	to 3200	to 6300	to 12500	to 25000
LIGHT	When normally working with approx.. 1/3 of W.L.L. and rarely with W.L.L.	ISO FEM	--	M1 1Dm	M2 1Cm	M3 1Bm	M4 1Am	M5 2m	M6 3m
MEDIUM	When normally working with approx.. 1/3 to 2/3 of W.L.L. and sometime W.L.L.	ISO FEM	M1 1Dm	M2 1Cm	M3 1Bm	M4 1Am	M5 2m	M6 3m	M7 4m
HEAVY	When normally working with approx.. to 2/3 of W.L.L. and often with W.L.L.	ISO FEM	M2 1Cm	M3 1Bm	M4 1Am	M5 2m	M6 3m	M7 4m	M8 5m
VERY HEAVY	When normally working with W.L.L. or near W.L.L.	ISO FEM	M3 1Bm	M4 1Am	M5 2m	M6 3m	M7 4m	M8 5m	--



SELF CLIMBING OR STANDARD SUSPENSION without any adjustments required. Swivel hooks on the chain and body reduces the risk of chain twist and allows easy positioning.



The **BODY** is made in cast aluminium to be as light, yet as strong as possible. The matte black finish is corrosion resistant and non reflective.



The **CHAIN-BAG BRACKET** allows the hoist to be used motor up or down. The design ensures the bag is positioned correctly to accept chain without the need for any adjustment, reducing the chance of chain spills.



EXTERNAL CHAIN GUIDE made from a special PVC is used to minimise the chance of chain jamming should the chain become twisted. This sacrificial plate helps protect both the chain and internal chain guides. (Extra Large body hoists are equipped with a steel guide plate).



CHAIN is a DAT type, RTS chain made of galvanized alloy steel grade 80 and complies with the standard DIN EN 818-7. Available in **BLACK** colour with T grade and DAT type. The quality is RTS and the surface is phosphate.

CHAIN HOIST

FEATURES

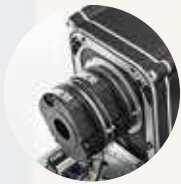

DOUBLE BRAKE. EXE Rise are supplied with double brake as standard. The brakes are supplied as complete units which allows for trouble free use and quick and easy inspection.



HANDLES. EXE Rise chain hoists have handles that work in either orientation. Regulations state handles shall be provided to make access to hoist the easy in any orientation.



IRON AND ASBESTOS FREE BRAKE shoes and stainless steel brake discs will not rust in the presence of moisture, preventing brake assemblies from seizing.



LOAD WHEEL. All EXE Rise chain hoists have load wheels with 5 pockets; this ensures compliance with European standards and delivers a smooth, quiet movement. Load wheels are heat treated.



CLUTCH OUTSIDE THE LOAD PATH positioned on the motor shaft in front of the motor assembly. With this arrangement, the brakes will hold the load in the unlikely event of a clutch failure.



VERY LOW OPERATIONAL NOISE, with just 67.5 dBA the EXE Rise chain hoist are very silent and now you can do take the quiet jobs.



GEAR BOX is manufactured with a thicker aluminum wall, comparing to the rest of the body, to respond to the very stringent mechanical requirements.



HERTZ/VOLT. EXE Rise chain hoist technical data have been calculated considering European power and control supply 230/400VAC - 3 - 50Hz. On request it is possible to have technical data at the different power and control supply and at the different frequency values.



BEARING GREASE on medium and large frame and **OIL** on extra large frame. They are high load, designed for the effective lubrication and protection of plain bearings and sliding surfaces used in extreme environments, particularly in heavily loaded.



EXE Rise hoists are **CE MARKED** in accordance with the requirements of the **MACHINERY DIRECTIVE 2006/42/EC.**

EXE
RISE

□ **D8+ 250 kg**

MEDIUM FRAME COMPACT

□ **D8+ 198kg** model also available ----

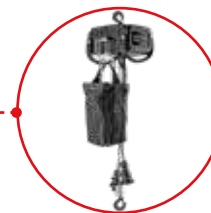

CHAIN HOIST

10



GENERAL FEATURES

Model	EXE Rise Chain Hoist D8+ 250kg
Type of Control	Direct or Low Voltage
FEM Class	2m
Duty Factor	40%
Start per Hour	240
Bearing Time /10 years	6300 h
Falls of Chain	1
Type of Chain	DIN EN 818-7 - type DAT - Zinc galvanized steel 80 grade
Size of Chain	5x15 mm
Chain Self-Weight	0.54 kg/m 0.36 lbs/ft
Safety Factor	8:1
IP Rate	55
Insulation Class (Temperature Class)	F in according to CEI 15-26
Load Wheel	5 pockets
Noise Level	67.5 dB @full load
Connection Cable Length	(75 ± 5) cm (2.6 ± 0.2) ft

EXE Rise Chain Hoist D8+ 250kg // Medium Frame Compact

The EXE Rise D8+ 250kg **compact medium frame** hoist is made from extremely light cast aluminum. Its low profile frame makes it ideal for squeezing into small spaces and achieving the greatest possible headroom in low-ceiling venues. This lightweight, compact hoist is ideal for wedding receptions, corporate event venues, and for simple rigs in educational, religious or theatrical settings.

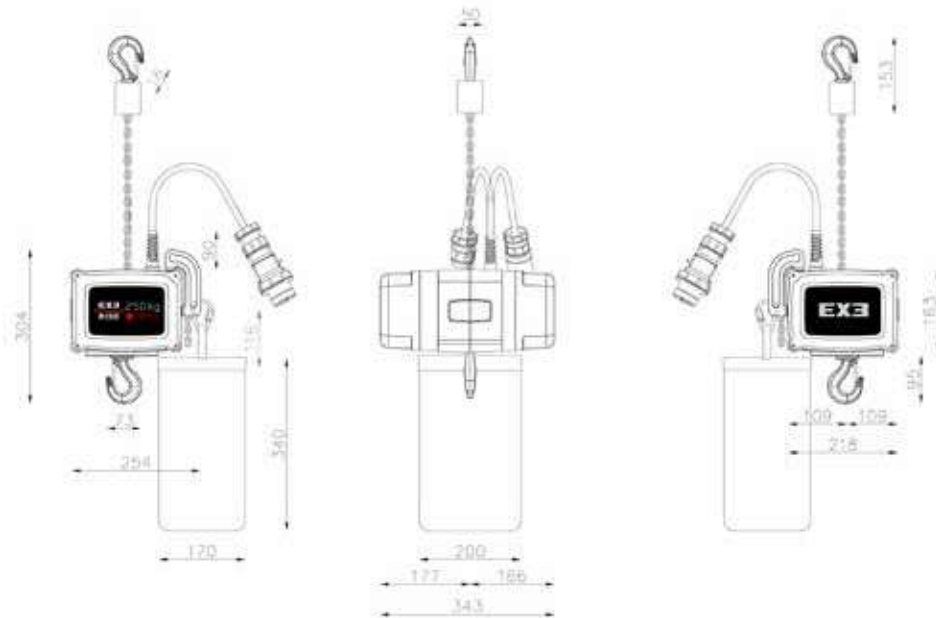
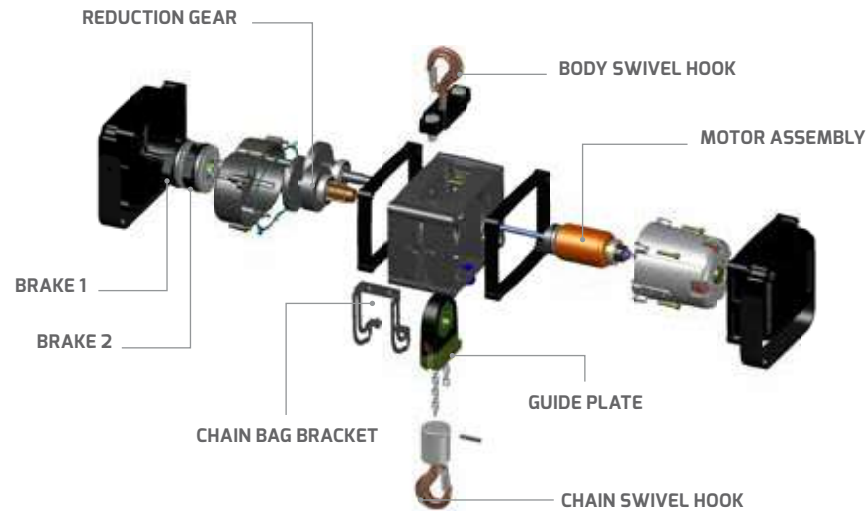

The values are reported in **mm**. DC model has only one cable.

EXE Rise Chain Hoist D8+ 250kg // Medium Frame Compact

□ D8+ 250kg DIRECT CONTROL

Working Load Limit	250 kg / 551 lbs
Frequency	50 Hz
Lifting Speed	4 m/min / 13 ft/min ± 1%
Motor Power	0.5 kW
Operating Voltage Δ/Y	230/400 VAC - 3 - 50 Hz
3 ph Current	Δ 2.94 A - Y 1.70 A
Δ Power Supply Connector (*)	CEE 16A 9h 230VAC - 3PH + G black plug
Y Power Supply Connector	CEE 16A 6h 400VAC - 3PH + G black plug
Revolutions Per Minute	1400
Number of Brakes	2
DC Brake Size	06
DC Brake Power	20 W
DC Brake Operating Voltage	103 VDC
DC Brake Rated Torque	4 Nm
DC Brake Rated Torque Reduction at the speed specification x %	87% (1500 r/min)
DC Brake gap (SL)	0.2 mm
Limit Switch (*)	2 positions
Self-Weight	DC - 21.5 kg / 47.4 lbs LVC - 23 kg / 50.7 lbs

(*) Only on request.

□ D8+ 250kg LOW VOLTAGE CONTROL

Control Supply Connector	CEE 16A 4h 24VAC - 3PH + G black socket
Limit Switch	2 positions
Encoder	On request

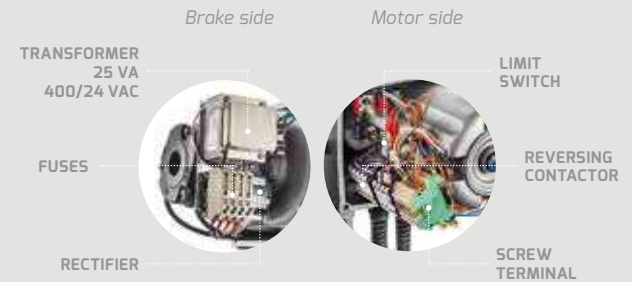

208 VAC - 3 - 60 Hz configuration is available.

OPEN UP compatible. Custom configuration are also possible.
Please refer to your local EXE Technology representative for all information.

EXE
RISE

□ **D8+ 500 kg**

MEDIUM FRAME



GENERAL FEATURES

Model	EXE Rise Chain Hoist D8+ 500kg
Type of Control	Direct or Low Voltage
FEM Class	2m
Duty Factor	40%
Start per Hour	240
Bearing Time /10 years	6300 h
Falls of Chain	1
Type of Chain	DIN EN 818-7 - type DAT - Zinc galvanized steel 80 grade
Size of Chain	6x18mm
Chain Self-Weight	0.78 kg/m 0.52 lbs/ft
Safety Factor	8:1
IP Rate	55
Insulation Class (Temperature Class)	F in according to CEI 15-26
Load Wheel	5 pockets
Noise Level	67.5 dB @full load
Connection Cable Length	(75 ± 5) cm (2.6 ± 0.2) ft

EXE Rise Chain Hoist D8+ 500kg // Medium Frame

The EXE Rise D8+ 500kg **medium frame** hoist is made from extremely light cast aluminum. It is small, but mighty with a self-weight of only 24 kg or 55 lbs. That's a lifting power of 20 times its self-weight making it ideal for soundstages, nightclubs, exhibition halls, concert halls, amphitheatres, and other outdoor venues.

EXE Rise Chain Hoist D8+ 500kg // Medium Frame

□ D8+ 500kg DIRECT CONTROL

Working Load Limit	500 kg / 1102 lbs
Frequency	50 Hz
Lifting Speed	4 m/min / 13 ft/min ± 1%
Motor Power	0.8 kW
Operating Voltage Δ/Y	230/400 VAC - 3 -50 Hz
3 ph Current	Δ 3.93 A - Y 2.27 A
Δ Power Supply Connector (*)	CEE 16A 9h 230VAC - 3PH + G black plug
Y Power Supply Connector	CEE 16A 6h 400VAC - 3PH + G black plug
Revolutions Per Minute	1400
Number of Brakes	2
DC Brake Size	06
DC Brake Power	20 W
DC Brake Operating Voltage	103 VDC
DC Brake Rated Torque	4 Nm
DC Brake Rated Torque Reduction at the speed specification x %	87% (1500 r/min)
DC Brake gap (SL)	0.2 mm
Limit Switch (*)	2 positions
Self-Weight	24 kg / 53 lbs

(*) Only on request.

□ D8+ 500kg LOW VOLTAGE CONTROL

Control Supply Connector	CEE 16A 4h 24VAC - 3PH + G black socket
Limit Switch	2 positions
Encoder	Incremental or Absolute

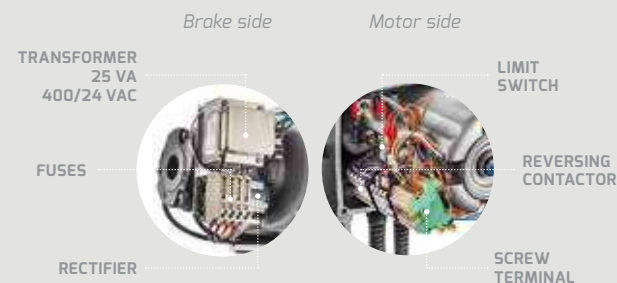

208 VAC - 3 - 60 Hz configuration is available.

OPEN UP compatible. Custom configuration are also possible. Please refer to your local EXE Technology representative for all information.

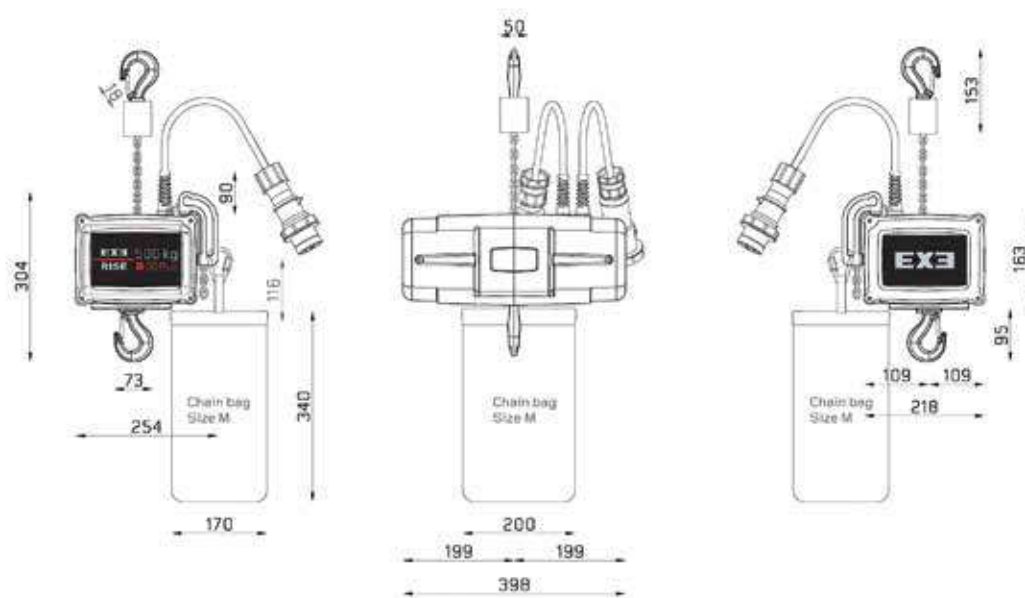
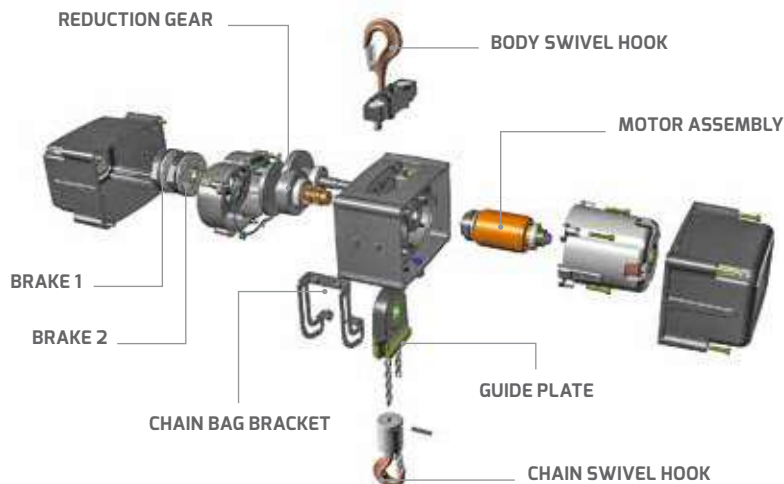

The values are reported in mm. DC model has only one cable.

EXE
RISE

□ **D8+ 1000 kg**

LARGE FRAME



GENERAL FEATURES

Model	EXE Rise Chain Hoist D8+ 1000kg
Type of Control	Direct or Low Voltage
FEM Class	2m
Duty Factor	40%
Start per Hour	240
Bearing Time /10 years	6300 h
Falls of Chain	1
Type of Chain	DIN EN 818-7 - type DAT - Zinc galvanized steel 80 grade
Size of Chain	8x24 mm
Chain Self-Weight	1.39 kg/m 0.93 lbs/ft
Safety Factor	8:1
IP Rate	55
Insulation Class (Temperature Class)	F in according to CEI 15-26
Load Wheel	5 pockets
Noise Level	67.5 dB @full load
Connection Cable Length	(75 ± 5) cm (2.6 ± 0.2) ft

EXE Rise Chain Hoist D8+ 1000kg // Large Frame

The EXE Rise D8+ 1000kg **large frame** single fall hoist is made by gravity casting is durably designed for a heavy duty life cycle. This hoist is everlasting with proper care and maintenance, which makes it ideal for the rugged life on-tour. It is a fantastic option for heavier grid systems often seen in festivals, outdoor venues, arenas, and film sets.

EXE Rise Chain Hoist D8+ 1000kg 2F // Large Frame

□ D8+ 1000kg DIRECT CONTROL

Working Load Limit	1000 kg / 2205 lbs
Frequency	50 Hz
Lifting Speed	4 m/min / 13 ft/min ± 1%
Motor Power	1.0 kW
Operating Voltage Δ/Y	230/400 VAC - 3 -50 Hz
3 ph Current	Δ 4.62 A - Y 2.67 A
Δ Power Supply Connector (*)	CEE 16A 9h 230VAC - 3PH + G black plug
Y Power Supply Connector	CEE 16A 6h 400VAC - 3PH + G black plug
Revolutions Per Minute	1400
Number of Brakes	2
DC Brake Size	08
DC Brake Power	25 W
DC Brake Operating Voltage	103 VDC
DC Brake Rated Torque	8 Nm
DC Brake Rated Torque Reduction at the speed specification x %	85% (1500 r/min)
DC Brake gap (SL)	0.2 mm
Limit Switch (*)	2 position s
Self-Weight	43 kg / 95 lbs

(*) Only on request.

□ D8+ 1000kg LOW VOLTAGE CONTROL

Control Supply Connector	CEE 16A 4h 24VAC - 3PH + G black socket
Limit Switch	2 positions
Encoder	Incremental or Absolute

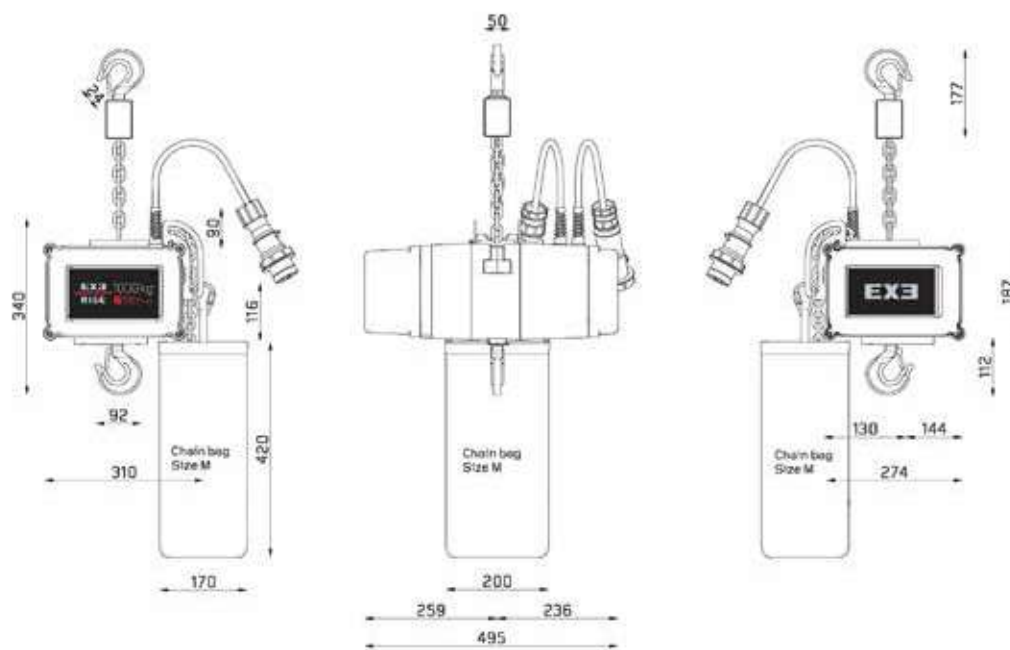
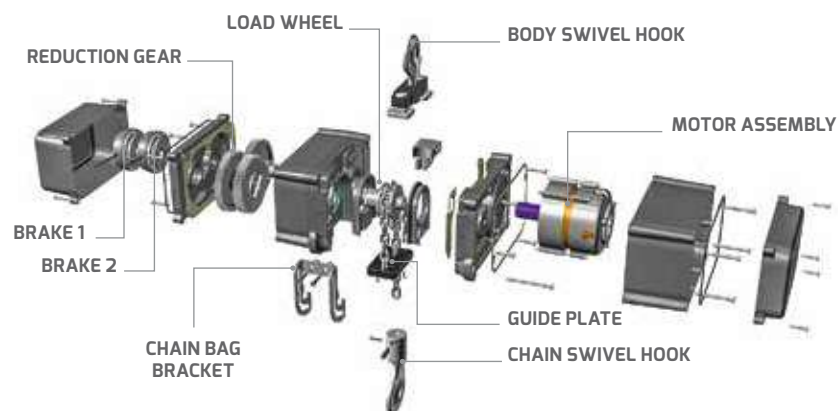

The values are reported in **mm**. DC model has only one cable.

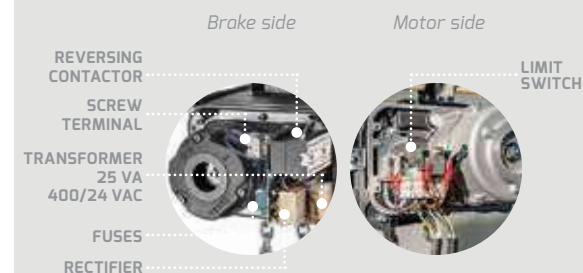

208 VAC - 3 - 60 Hz configuration is available.

OPEN UP compatible. Custom configuration are also possible. Please refer to your local EXE Technology representative for all information.

EXE
RISE

□ **D8+ 2000 kg**
2 REEVES

LARGE FRAME



GENERAL FEATURES

Model	EXE Rise Chain Hoist D8+ 2000kg 2F
Type of Control	Direct or Low Voltage
FEM Class	2m
Duty Factor	40%
Start per Hour	240
Bearing Time /10 years	6300 h
Falls of Chain	2
Type of Chain	DIN EN 818-7 - type DAT - Zinc galvanized steel 80 grade
Size of Chain	8x24mm
Chain Self-Weight	1.39 kg/m 0.93 lbs/ft
Safety Factor	8:1
IP Rate	55
Insulation Class (Temperature Class)	F in according to CEI 15-26
Load Wheel	5 pockets
Noise Level	67.5 dB @full load
Connection Cable Length	(75 ± 5) cm (2.6 ± 0.2) ft

EXE Rise Chain Hoist D8+ 2000Kg // Large Frame

The EXE Rise D8+ 2000kg **large frame** double fall hoist is made by gravity casting is durably designed for a heavy duty life cycle. This hoist is everlasting with proper care and maintenance, which makes it ideal for the rugged life on-tour. It is a fantastic option for heavier grid systems often seen in festivals, outdoor venues, arenas, and film sets.

EXE Rise Chain Hoist D8+ 2000kg 2F // Large Frame

□ D8+ 1000kg DIRECT CONTROL

Working Load Limit	2000 kg / 4409 lbs
Frequency	50 Hz
Lifting Speed	4 m/min / 13 ft/min ± 1%
Motor Power	1.6 kW
Operating Voltage Δ/Y	230/400 VAC - 3 -50 Hz
3 ph Current	Δ 8.37 A - Y 4.83 A
Δ Power Supply Connector (*)	CEE 16A 9h 230VAC - 3PH + G black plug
Y Power Supply Connector	CEE 16A 6h 400VAC - 3PH + G black plug
Revolutions Per Minute	1400
Number of Brakes	2
DC Brake Size	10
DC Brake Power	30 W
DC Brake Operating Voltage	103 VDC
DC Brake Rated Torque	16 Nm
DC Brake Rated Torque Reduction at the speed specification x %	83% (1500 r/min)
DC Brake gap (SL)	0.2 mm
Limit Switch (*)	2 positions
Self-Weight	45 kg / 99 lbs

(*) Only on request.

□ D8+ 1000kg LOW VOLTAGE CONTROL

Control Supply Connector	CEE 16A 4h 24VAC - 3PH + G black socket
Limit Switch	2 positions
Encoder	Incremental or Absolute

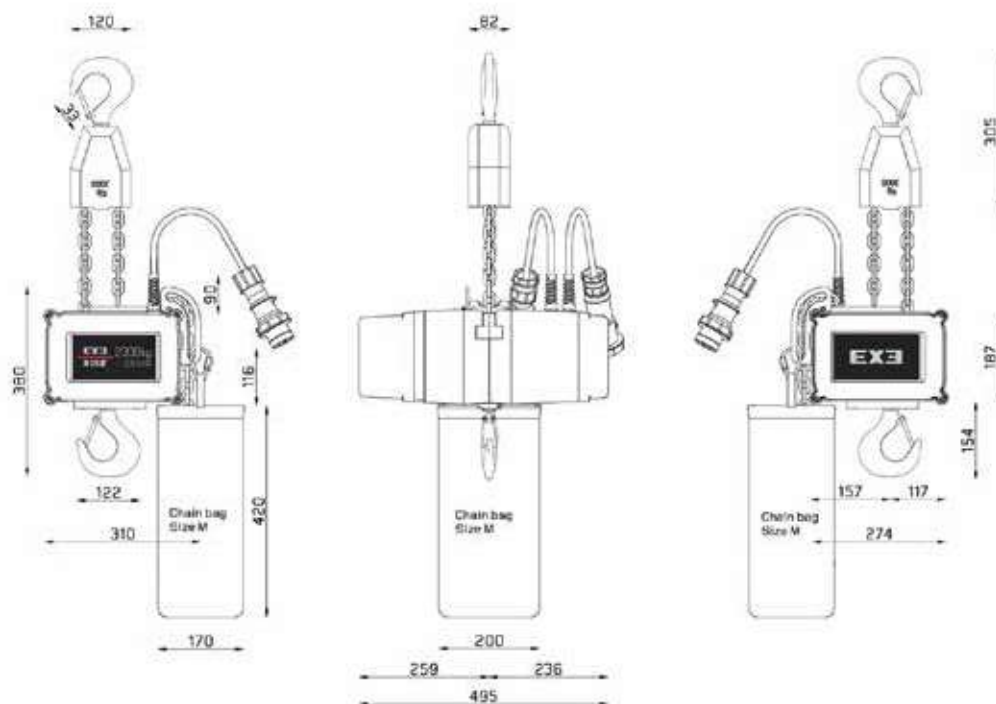
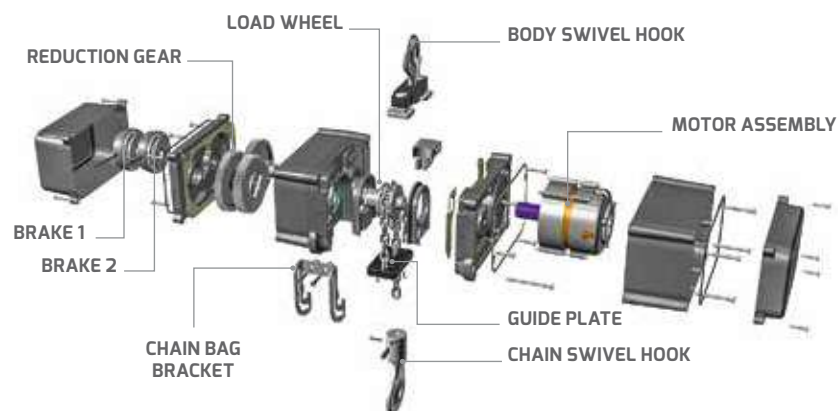

The values are reported in mm. DC model has only one cable.

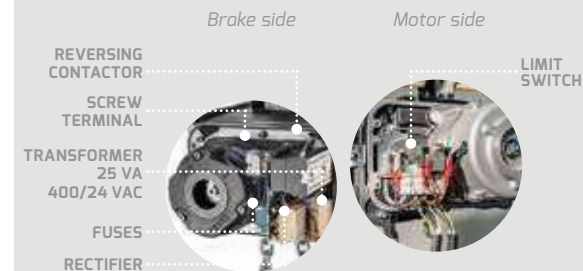

208 VAC - 3 - 60 Hz configuration is available.

OPEN UP compatible. Custom configuration are also possible. Please refer to your local EXE Technology representative for all information.

EXE
RISE

□ **D8+ 1600kg**

1 REEVE

EXTRA LARGE FRAME COMPACT



GENERAL FEATURES

Model	EXE Rise Chain Hoist D8+ 1600kg
Type of Control	Direct or Low Voltage
FEM Class	3m
Duty Factor	50%
Start per Hour	300
Bearing Time /10 years	12500 h
Falls of Chain	1
Type of Chain	DIN EN 818-7 - type DAT - Zinc galvanized steel 80 grade
Size of Chain	10x28 mm
Chain Self-Weight	2.24 kg/m 1.51 lbs/ft
Safety Factor	8:1
IP Rate	55
Insulation Class (Temperature Class)	F in according to CEI 15-26
Load Wheel	5 pockets
Noise Level	67.5 dB @full load
Connection Cable Length	(75 ± 5) cm (2.6 ± 0.2) ft

EXE Rise Chain Hoist D8+ 1600kg // Extra Large Frame Compact

When one-ton isn't enough capacity, but you don't want the monstrosity of a bulkier extra large frame, there's the EXE Rise 1.6 ton COMPACT XL frame hoist. This beauty has been expertly designed to retain an 8-to-1 safety factor in conformance with D8+ requirements while maintaining its figure. Fashionably safer with a single fall chain to avoid the risk of unintentional twist, which is common with double-reeved hoists. There's enough for you to double-, triple-, quadruple-check. This very capable hoist has a FEM class rating of 3m. Use it for large outdoor structures and permanent installations.

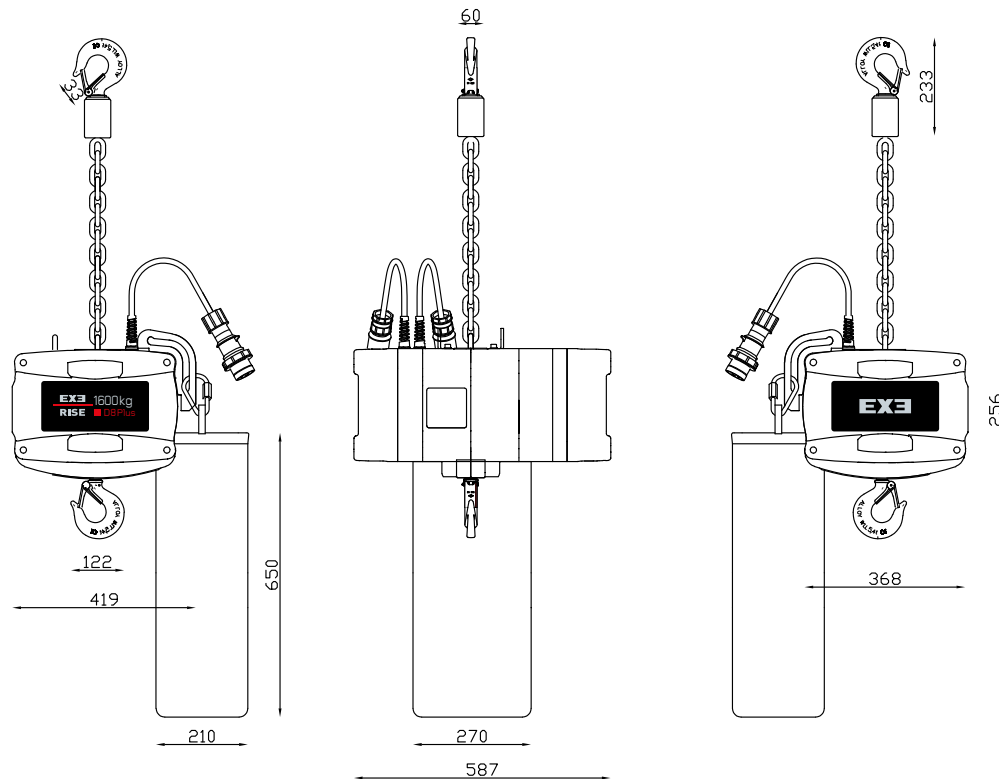
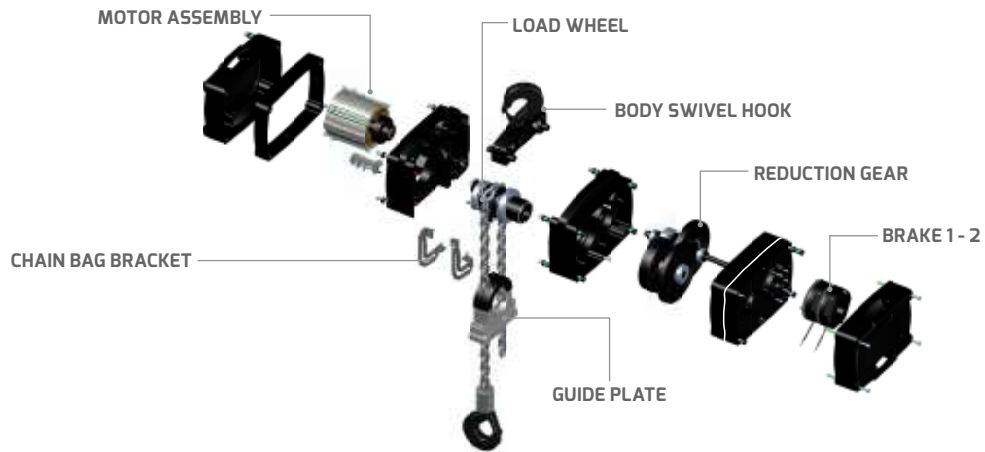

The values are reported in **mm**. DC model has only one cable.

EXE Rise Chain Hoist D8+ 1600kg // Extra Large Frame Compact

□ D8+ 1600kg DIRECT CONTROL

Working Load Limit	1600 kg / 3527 lbs
Frequency	50 Hz
Lifting Speed	4 m/min / 13 ft/min ± 1%
Motor Power	2.0 kW
Operating Voltage Δ/Y	230/400 VAC - 3 - 50 Hz
3 ph Current	Δ 9.9 A - Y 5.7 A
Δ Power Supply Connector (*)	CEE 16A 9h 230VAC - 3PH + G black plug
Y Power Supply Connector	CEE 16A 6h 400VAC - 3PH + G black plug
Revolutions Per Minute	1400
Number of Brakes	2
DC Brake Size	10
DC Brake Power	30 W
DC Brake Operating Voltage	103 VDC
DC Brake Rated Torque	16 Nm
DC Brake Rated Torque Reduction at the speed specification x %	83% (1500 r/min)
DC Brake gap (SL)	0.2 mm
Self-Weight	110 kg / 243 lbs
Limit Switch	2 Positions
Encoder	Incremental or Absolute

(*) Only on request.

□ D8+ 1600kg LOW VOLTAGE CONTROL

Control Supply Connector	CEE 16A 4h 24VAC - 3PH + G black socket
--------------------------	--

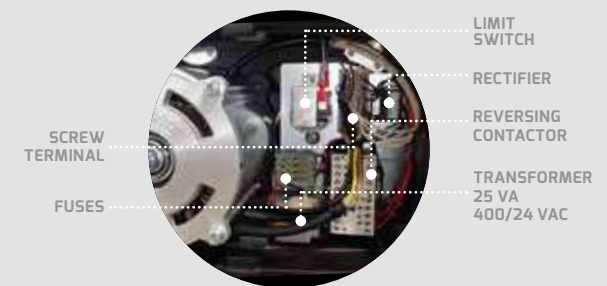

208 VAC - 3 - 60 Hz configuration is available.

OPEN UP compatible. Custom configuration are also possible. Please refer to your local EXE Technology representative for all information.

EXE
RISE

□ **D8+ 2000 kg**
1 REEVE

EXTRA LARGE FRAME

CHAIN HOIST

20



GENERAL FEATURES

Model	EXE Rise Chain Hoist D8+ 2000kg
Type of Control	Direct or Low Voltage
FEM Class	3m
Duty Factor	50%
Start per Hour	300
Bearing Time /10 years	12500 h
Falls of Chain	1
Type of Chain	DIN EN 818-7 - type DAT - Zinc galvanized steel 80 grade
Size of Chain	11.3x31 mm
Chain Self-Weight	2.85 kg/m 1.91 lbs/ft
Safety Factor	8:1
IP Rate	55
Insulation Class (Temperature Class)	F in according to CEI 15-26
Load Wheel	5 pockets
Noise Level	67.5 dB @full load
Connection Cable Length	(75 ± 5) cm (2.6 ± 0.2) ft

EXE Rise Chain Hoist 1 Reeve 2000kg //Extra Large Frame

The **Extra Large Frame** EXE RISE Chain Hoist 2 ton single reeve is extremely strong, corrosion resistant and no-reflective as possible due to the body made from cast aluminium with matt black finish. Handling and lifting of the chain hoist is facilitated by handles that work in either operational orientation. The possibility of using the chain hoist in both Standard and Self Climbing positions, combined with its swivel or fixed hook feature, increase practicality and versatility.

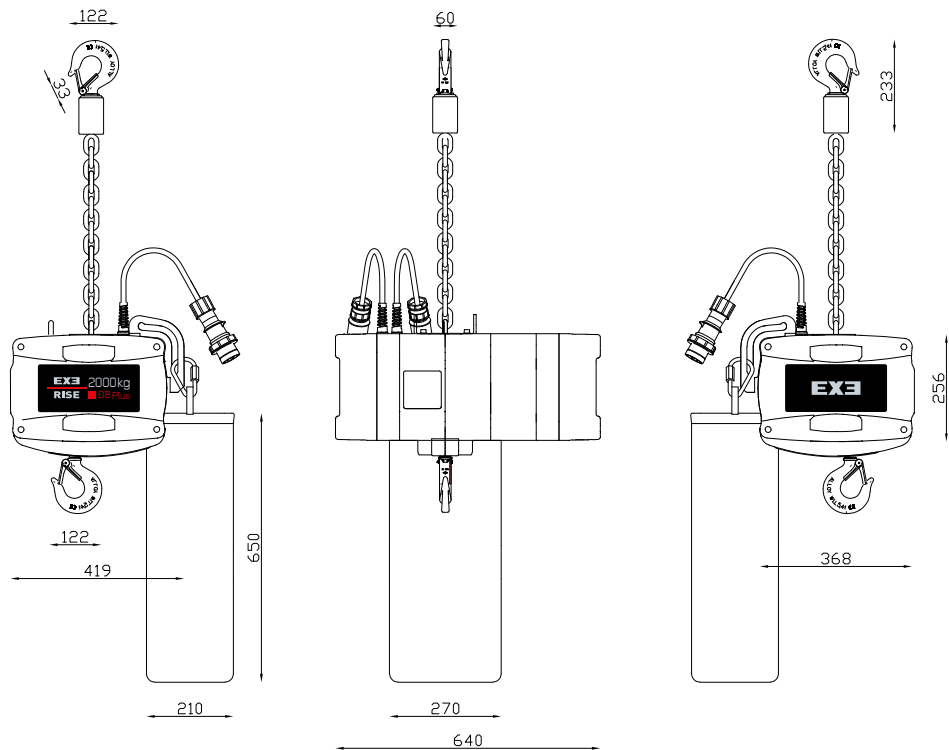
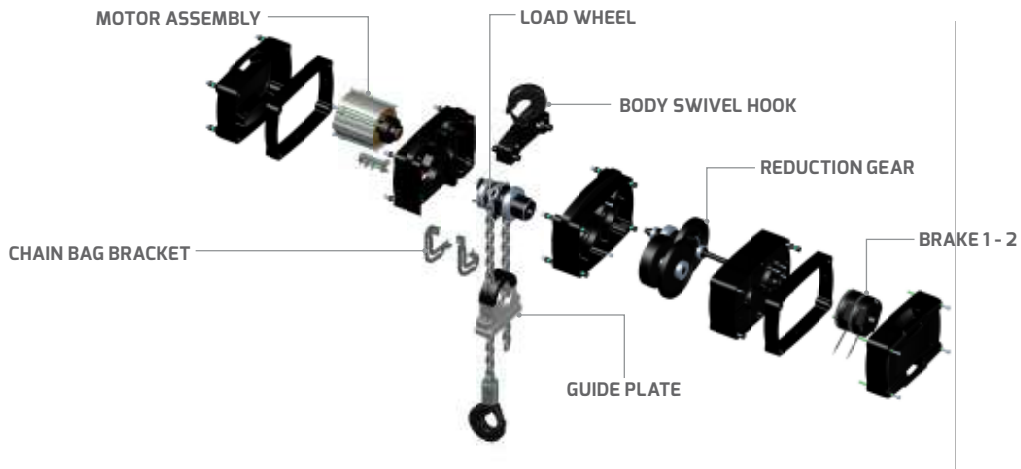

The values are reported in **mm**. DC model has only one cable.

EXE Rise Chain Hoist D8+ 2000kg 1F // Extra Large Frame

□ D8+ 2000kg DIRECT CONTROL

Working Load Limit	2000 kg / 4409 lbs
Frequency	50 Hz
Lifting Speed	4 m/min / 13 ft/min ± 1%
Motor Power	2.0 kW
Operating Voltage Δ/Y	230/400 VAC - 3 -50 Hz
3 ph Current	Δ 9.9 A - Y 5.7 A
Δ Power Supply Connector (*)	CEE 16A 9h 230VAC - 3PH + G black plug
Y Power Supply Connector	CEE 16A 6h 400VAC - 3PH + G black plug
Revolutions Per Minute	1400
Number of Brakes	2
DC Brake Size	12
DC Brake Power	40 W
DC Brake Operating Voltage	103 VDC
DC Brake Rated Torque	32 Nm
DC Brake Rated Torque Reduction at the speed specification x %	81% (1500 r/min)
DC Brake gap (SL)	0.3 mm
Self-Weight	123 kg / 271 lbs
Limit Switch	2 position
Encoder	Incremental or Absolute

(*) Only on request.

□ D8+ 2000kg LOW VOLTAGE CONTROL

Control Supply Connector	CEE 16A 4h 24VAC - 3PH + G black socket
--------------------------	--

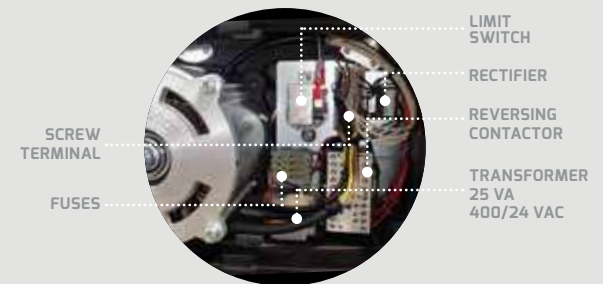

208 VAC - 3 - 60 Hz configuration is available.

OPEN UP compatible. Custom configuration are also possible.
Please refer to your local EXE Technology representative for all information.

EXE
RISE

□ **D8+ 2500kg**
1 REEVE

EXTRA LARGE FRAME



GENERAL FEATURES

Model	EXE Rise Chain Hoist D8+ 2500kg
Type of Control	Direct or Low Voltage
FEM Class	3m
Duty Factor	50%
Start per Hour	300
Bearing Time /10 years	12500 h
Falls of Chain	1
Type of Chain	DIN EN 818-7 - type DAT - Zinc galvanized steel 80 grade
Size of Chain	13x36 mm
Chain Self-Weight	3.80 kg/m 2.55 lbs/ft
Safety Factor	8:1
IP Rate	55
Insulation Class (Temperature Class)	F in according to CEI 15-26
Load Wheel	5 pockets
Noise Level	67.5 dB @full load
Connection Cable Length	(75 ± 5) cm (2.6 ± 0.2) ft

EXE Rise Chain Hoist 1 Reeve 2500kg // Extra Large Frame

The EXE Rise 2 and a half ton extra large frame hoists have a FEM class rating of 3m and are single reeved, maintaining an 8-to-1 safety factor. These hoists are ideal for some of the heaviest rigs such as line arrays, LED walls, scoreboards, complex mothergrids, and epic EDM festivals. If needed, these hoists can be manufactured with a double-reeved chain to double the load capacity for roof systems.

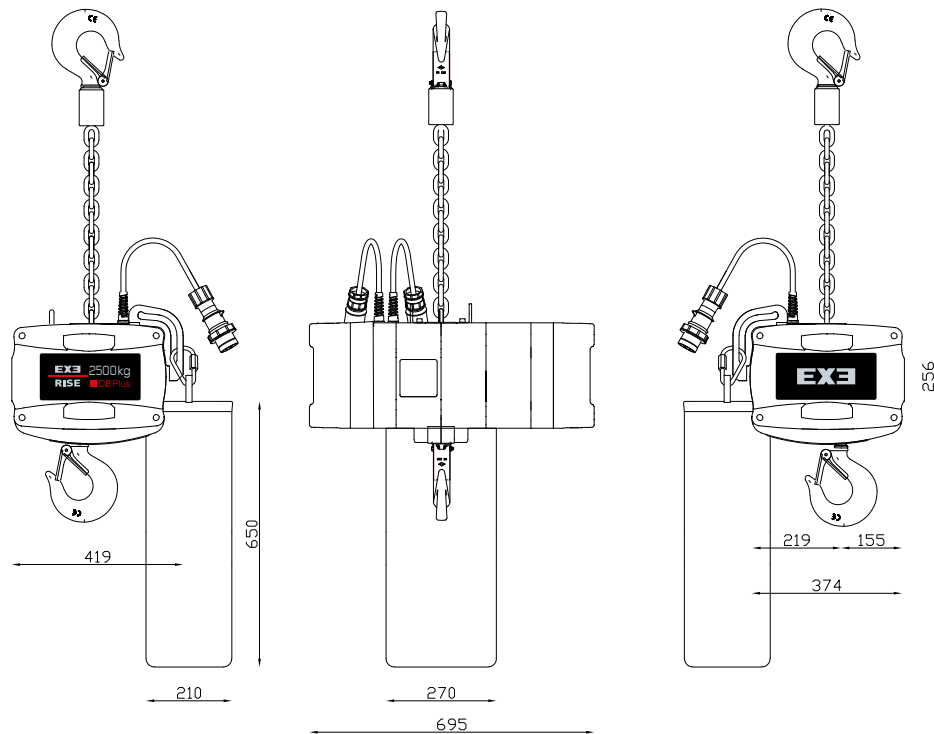
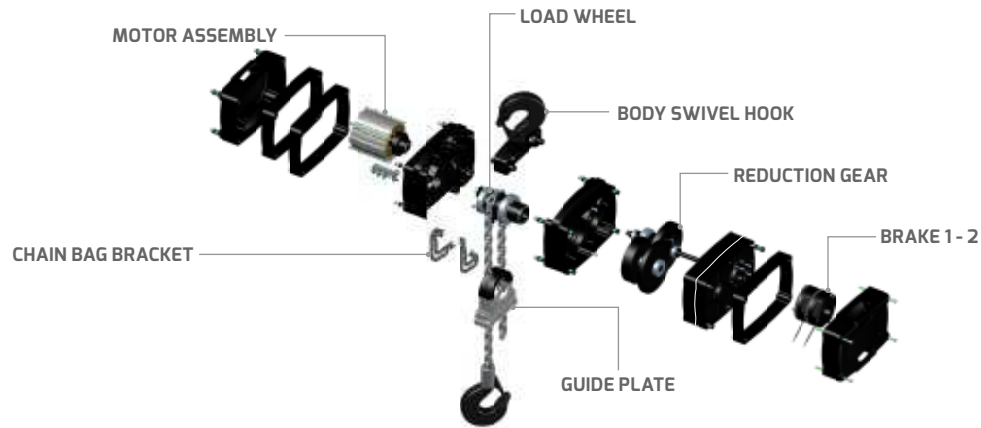

The values are reported in **mm**. DC model has only one cable.

EXE Rise Chain Hoist D8+ 2500kg // Extra Large Frame

□ D8+ 2500kg DIRECT CONTROL

Working Load Limit	2500 kg / 5512 lbs
Frequency	50 Hz
Lifting Speed	4 m/min / 13 ft/min ± 1%
Operating Voltage Δ/Y	230/400 VAC - 3 - 50 Hz
Δ Power Supply Connector (*)	CEE 16A 9h 230VAC - 3PH + G black plug
Y Power Supply Connector	CEE 16A 6h 400VAC - 3PH + G black plug
Revolutions Per Minute	1400
Number of Brakes	2
FEM Class	3m
Duty Factor	50%
Start per Hour	300
Bearing Time /10 years	12500 h
Falls of Chain	1
Type of Chain	DIN EN 818-7 - type DAT - Zinc galvanized steel 80 grade
Size of Chain	13x36 mm
Chain Self-Weight	3.80 kg/m 2.55 lbs/ft
Limit Switch	2 positions
Encoder	Incremental or Absolute

□ D8+ 2500kg LOW VOLTAGE CONTROL

Control Supply Connector	CEE 16A 4h 24VAC - 3PH + G black socket
--------------------------	---

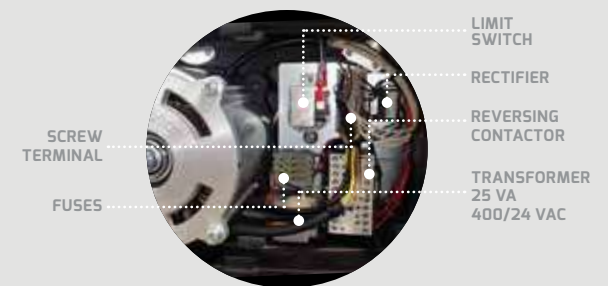

208 VAC - 3 - 60 Hz configuration is available.

OPEN UP compatible. Custom configuration are also possible. Please refer to your local EXE Technology representative for all information.

**EX3
RISE**

□ D8+ 250 kg

SINGLE PHASE

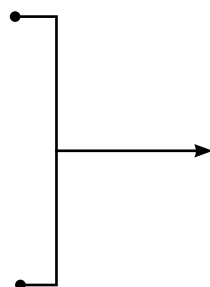

Single phase EXE Rise chain hoist designed around our medium size body, with a WLL of 250 kg. Ideal for many locations where 3 phase power might not be available.

230VAC

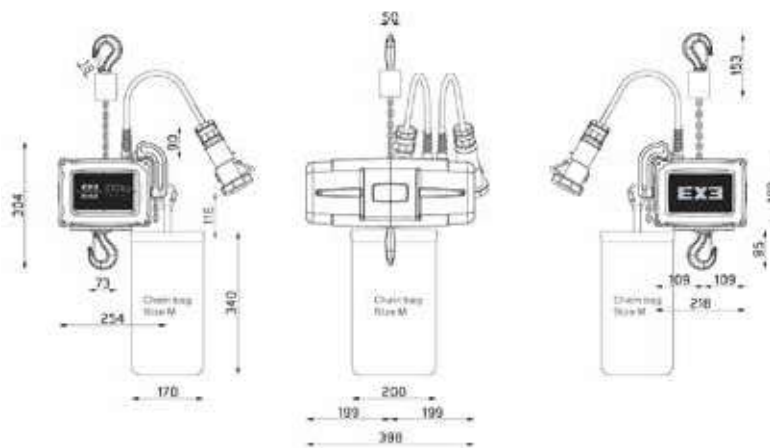

**EXE Rise Chain Hoist 250kg
// Single Phase**

□ D8+ 250kg SINGLE PHASE

Model	D8+ 250kg SINGLE PHASE
Working Load Limit (WLL)	250 kg / 551 lbs
Frequency	50 Hz
Lifting Speed	4 m/min / 13 ft/min ± 1%
Motor Power	0.8 kW
Operating Voltage	Δ 230 VAC - 1 - 50Hz
1 ph Current	Δ 3.1 A
Revolutions Per Minute	1400
Number of Brakes	2
DC Brake Size	06
DC Brake Power	20 W
DC Brake Operating Voltage	103 VDC
DC Brake Rated Torque	4 Nm
DC Brake Rated Torque Reduction at the speed specification x %	87% (1500 r/min)
DC Brake gap (SL)	0.2 mm
Self-Weight	24 kg / 53 lbs
FEM Class	2m
Duty Factor	40%
Start per Hour	240
Bearing Time /10 years	6300 h
Falls of Chain	1
Type of Chain	DIN EN 818-7 - type DAT-Zinc galvanized steel 80 grade
Size of Chain	6x18mm
Chain Self-Weight	0.78 kg/m 0.52 lbs/ft
Safety Factor	8:1
IP Rate	55
Insulation Class (Temperature Class)	F in according to CEI 15-26
Load Wheel	5 pockets
Noise Level	67.5 dB @full load
Connection Cable Length	(75 ± 5) cm (2.6 ± 0.2) ft

The values are reported in mm.

EX3
RISE

□ D8+ 500kg

SINGLE PHASE

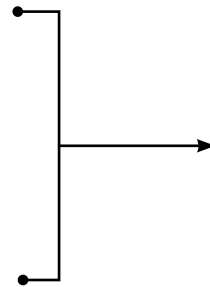

Single phase EXE Rise chain hoist designed around our medium size body, with a WLL of 500kg and inverter. Ideal for many locations where 3 phase power might not be available.

230VAC

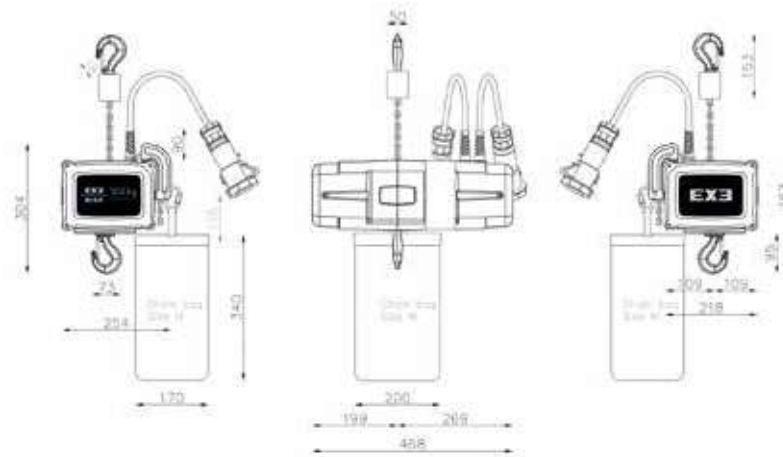

The values are reported in mm.

**EXE Rise Chain Hoist 500kg
WITH INVERTER
// Single Phase**

□ D8+ 500kg SINGLE PHASE

Model	D8+ 500kg SINGLE PHASE
Working Load Limit (WLL)	500 kg / 1102 lbs
Frequency	50 Hz
Lifting Speed	4 m/min / 13 ft/min ± 1%
Motor Power	0.8 kW
Operating Voltage	Δ 230 VAC - 1 - 50Hz
1 ph Current	Δ 6.0 A
Revolutions Per Minute	1400
Number of Brakes	2
DC Brake Size	06
DC Brake Power	20 W
DC Brake Operating Voltage	103 VDC
DC Brake Rated Torque	4 Nm
DC Brake Rated Torque Reduction at the speed specification x %	87% (1500 r/min)
DC Brake gap (SL)	0.2 mm
Self-Weight	27 kg / 59.5 lbs
FEM Class	2m
Duty Factor	40%
Start per Hour	240
Bearing Time /10 years	6300 h
Falls of Chain 1	
Type of Chain	DIN EN 818-7 - type DAT Zinc galvanized steel 80 grade
Size of Chain	6x18mm
Chain Self-Weight	0.78 kg/m 0.52 lbs/ft
Safety Factor	8:1
IP Rate	55
Insulation Class	F in according to CEI 15-26 (Temperature Class)
Load Wheel	5 pockets
Noise Level	67.5 dB @full load





EX3 500 kg
RISE DDPush

EX3 250 kg
RISE DDPush

E
D



Flight cases are extremely robust with protection against bumps and vibration. Parts are assembled using aluminum bordering, handles, closures and casing, with fixed wheels and trans pallet supports. Flight cases are fireproof and waterproof.

	M	L
A4I Code	XRFMFC2N	XRFLF1N
<i>Dimensions B1xB2xH (cm)</i>	74x57x58 cm	74x57x58 cm
<i>Dimensions B1xB2xH (Inch)</i>	29.1x22.4x22.8 inch	29.1x22.4x22.8 inch
<i>Quantity of Hoist</i>	2	1
<i>EXE Rise Hoists Compatibility</i>	Medium Frame Compact Medium Frame	Large Frame



XRFMFC2N



XRFLF1N

FLIGHT CASE



Flight cases are extremely robust with protection against bumps and vibration. Parts are assembled using aluminum bordering, handles, closures and casing, with fixed wheels and trans pallet supports. Flight cases are fireproof and waterproof.

	XLA	XLB	XLC
A4I Code	XRFXF1NA	XRFXF1NB	XRFXF1NC
<i>Dimensions B1xB2xH (cm)</i>	85x65x82 cm	113x80x73 cm	80x80x73 cm
<i>Dimensions B1xB2xH (inch)</i>	33.5x25.6x32.3 inch	44.5x31.5x28.7 inch	31.5x31.5x28.7 inch
<i>Quantity of Hoist</i>	1	1	1
<i>EXE Rise Hoists Compatibility</i>	ExtraLarge Frame	ExtraLarge Frame	ExtraLarge Frame



XRFXF1NB



XRFXF1NC

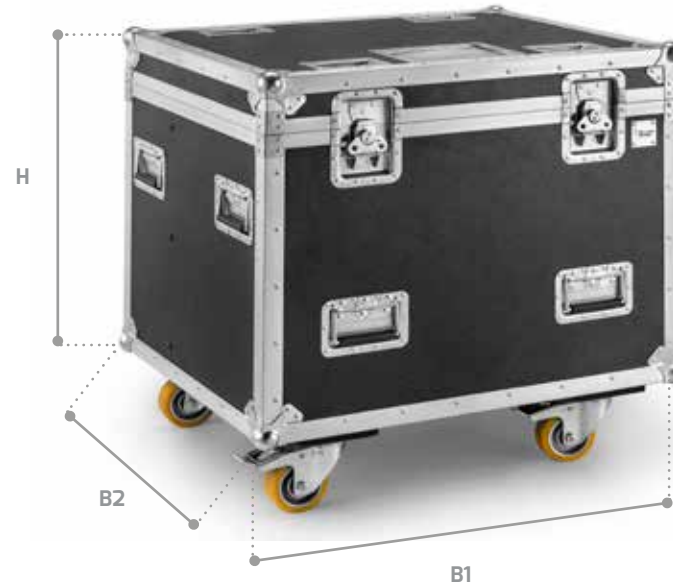

XRFXF1NA



Chain Bag used for EXE-RISE is in Polyvinyl chloride coated polyamide 65% PVC (Nylon 840), 35% Polyamide. There are many sizes from X5 up to XXXL, depending on the size and weight of the chain

	X5	S-	S	M	L
A4I Code	CHB029	CBH059	CHB024	CHB025	CHB026
External Dimensions [cm] = Ax B	14x9	20x17	20x17	20x17	20x17
Height [cm] = C	40	17	34	42	58
Self-Weight [kg]	≈ 0.75	≈ 1.00	≈ 1.00	≈ 1.00	≈ 1.00
External Dimensions [inch] = Ax B	5.5x3.5	7.9x6.7	7.9x6.7	7.9x6.7	7.9x6.7
Height [inch] = C	15.7	6.7	13.4	16.5	22.8
Self-Weight [lbs]	≈ 1.65	≈ 2.20	≈ 2.20	≈ 2.20	≈ 2.20

	L+	XL	XXL	XXXL
A4I Code	CHB051	CHB028	CHB056	CHB056
External Dimensions [cm] = Ax B	27x21	27x21	20x25/20x40	20x20/20x40
Height [cm] = C	55	65	80	115
Self-Weight [kg]	≈ 0.75	≈ 1.00	≈ 1.50	≈ 10
External Dimensions [inch] = Ax B	10.6x8.3	10.6x6.7	7.9x9.8/7.9x15.7	7.9x9.8/7.9x13.7
Height [inch] = C	21.7	25.6	31.5	45.3
Self-Weight [lbs]	≈ 1.65	≈ 2.20	≈ 3.31	≈ 22.0

RAIN COVER



STANDARD POSITION:

Protection from solids and liquids element for EXE Rise chain hoist in OFF mode during seasonal and permanent installations. EXE Technology cover can be used in the motor-up position and fit easily over the top of the motor to form an impermeable barrier.

	S	M	L
<i>A4I Code</i>	CHHSBK	CHHMBK	CHHLBK
<i>Commercial Name</i>	Black Cover Small	Black Cover Medium	Black Cover Large
<i>Chain Hoist Compatible</i>	SMALL FRAME	MEDIUM FRAME	LARGE FRAME



CLIMBING POSITION:

Protection from solids and liquids element for EXE Rise chain hoist in OFF mode during seasonal and permanent installations. EXE Technology cover can be used in the motor-down position and fit easily over the top of the motor to form an impermeable barrier.

	M	L
<i>A4I Code</i>	CHHRCM	CHHRCL
<i>Commercial Name</i>	Black Rain Cover Medium	Black Rain Cover Large
<i>Chain Hoist Compatible</i>	MEDIUM FRAME	LARGE FRAME

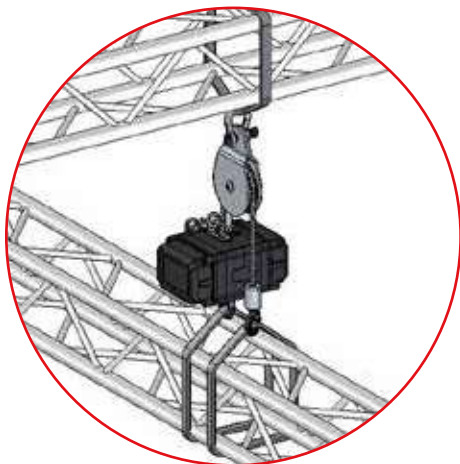

DOUBLE REEVE ADAPTOR

The external double reeve adaptor for medium frame and medium frame compact, that allows you to double the load capacity, halving the speed.

<i>Chain Size</i>	5x15 mm	6x18 mm
<i>Hoist Compatibility</i>	Medium Frame Compact	Medium Frame



CHAIN TESTING GAUGE

As the owner of a hoist, you are required to continuously monitor the wear and tear on your hoist chain in accordance with DIN 685 T5 or ISO 7592. A chain may have reached its service life end due to wear of its single or multiple link pitch attachments; wear of the wire diameter, and/or plastic deformation of its chain links due to overloading.

EXE limit gauge consists of an aluminium strip with guide holes for the measuring pins as well as locking holes for the locking studs attached to the measuring pin.

The two galvanised measuring pins provided with locking studs are located, together with the limit gauge, in a high quality softshell bag.

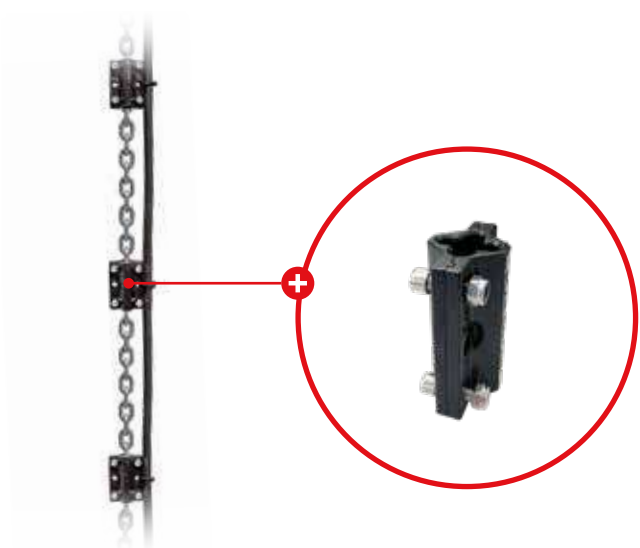

CHAIN SLIDER

Dual 9mm cable attachment points. Can be fitted on a load-bearing chain. Made out of low friction black Polyoxymethylene (POM). Four stainless M6 Hex bolts and Nylocks included. The shackle is not included.

	S	M	L
<i>A4I Code</i>	RGCSM	RGCSMD	RGCSLG
<i>Commercial Name</i>	Chain Slider Small	Chain Slider Medium	Chain Slider Large
<i>Chain Compatible</i>	4x12mm 5x15mm	6x18mm 7x22mm	8x24mm



TOURING SLIDER

The touring slider is designed for cable management in entertainment rigging system. It is made in one piece with two fixing points for cable such as power, control, data or audio cables to get attached. No tool is required whilst putting chain slider in the chain.

	S	M	L	XL
<i>A4I Code</i>	RGCSM	RGCSMD	RGCSLG	RGCSXL
<i>Commercial Name</i>	Chain Slider Small	Chain Slider Medium	Chain Slider Large	Chain Slider Extra Large
<i>Chain Compatible</i>	4x12mm 5x15mm	6x18mm 7x22mm	8x24mm	10x28mm 11.3x31mm 13x36mm



SELF LOCKING SWIVEL HOOKS

The self locking swivel hooks are extremely safe because of the self closing latch and the way the hook is constructed prevents the hook from opening when under load. (Available in black and red color)

	S	M	L
<i>Commercial Name</i>	Latch Lock Hook Small	Latch Lock Hook Medium	Latch Lock Hook Large
<i>Chain Hoist Compatible</i>	MEDIUM FRAME COMPACT MEDIUM FRAME	LARGE FRAME 1 REEVE	EXTRA LARGE FRAME 1 REEVE



FIXED HOOK

The fixed body hook is the alternative to the swivel one when the latter is not suitable for your installation.

<i>Chain Hoist Compatibility</i>	Medium Frame Compact	Medium Frame
----------------------------------	----------------------	--------------



ENCODER

INCREMENTAL ENCODER

Most of the incremental encoders produce square waves signals but also sinusoidal signals and can provide travel, position, displacement and velocity information; positional information is relative, this means that it is possible to know both if the axis is rotating and if it is rotating clockwise or counterclockwise; but it is not possible to gather information about the absolute position of the axis. For this reason the homing operation is always required at the beginning of the process to determine the absolute position of the system (detection of the reference point or zero point). Information is expressed in pulses per revolution (PPR).

ABSOLUTE ENCODER

An absolute encoder is designed to output the absolute position information; it has a unique code pattern, thus it can provide a unique digital code for each angular position of the axis. The main feature is that it is always possible to know exactly the position of the axis. For instance, if you turn off the power supply and move the encoder shaft or the device, then at power on the absolute encoder will output the current position of the axis precisely. This means that no homing operation is required to determine the absolute position.

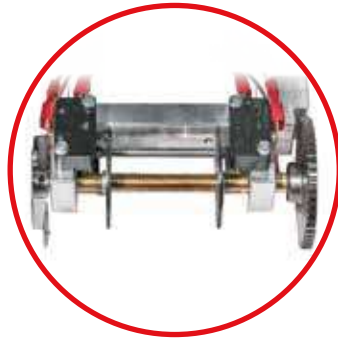

LIMIT SWITCH - DIRECT CONTROL

More assured using EXE RISE chain hoists with the latest innovative component, the EXE DC Limit Switch Control Module. The new accessory provides a higher level of safety and protection for our medium and large frame chain hoists, combining features from LVC chain hoists and high-specification motor-controllers.

Key features:

- Missing phase detection monitoring
- Automatic power supply sequence recognition
- DC Chain Hoist with limit switch
- Only one cable required to each DC hoist
- Directly compatible with EXE Drive DC Controller



DATA LOGGER

The EXE Data Logger is an innovative device records the real time and lifetime hours, minutes, and seconds of operation, start cycles, real time temperature and relative humidity values as well as the peak temperature and humidity values. No batteries required. The Data Logger uses the same power source as the hoist circuit and is activated when the hoist is running, and the information is stored within the onboard RAM. The EXE Data Logger can be retrofitted to your existing EXE Technology inventory

EXE HAND CHAIN BLOCK

**LIGHTWEIGHT,
NOT POWERED & EASY TO CARRY**



The EXE HCB Hand Chain Block is the new family of products, designed to lift loads where it is not possible to use electric chain hoists.

The EXE HCB Hand Chain Hoists compact in size and very light, making it easy to transport and handle. It's operated by hand and is widely used for lifting heavy loads without needing the power supply. Thanks to the careful choice of materials. To being used alone, it can also be used with other lifting products. Available with 1000kg capacity and with 18 meters of chain.

The EXE HCB Hand Chain Block not only has reasonable structural design, high performance strength, but also has the advantages of safety, reliability, easy maintenance and durability.

02



EXE
HCB

HCB 1000kg

HAND CHAIN BLOCK



BLACK CHASSIS



LOAD WHEEL



CHAIN



CHAIN HOOK

GENERAL FEATURES

Model	EXE HCB Hand Chain Block 1000kg
Type	Manual hoist
WLL	1000kg
Load Chain size	6x18mm
Load Chain length	18m
Hand Chain length	36m
Body Colour	Black

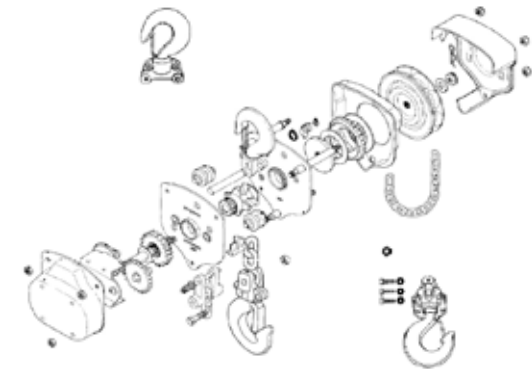

EXE IBEAM

BEAM TROLLEY SYSTEM



The EXE iBeam Trolleys are a mobile anchorage point that can be fitted onto a lifting beam to suspend lifting equipment beneath, such as a chain hoist. This allows the load to travel along the direction of the lifting beam.

The EXE iBeam Trolleys are designed for HEA/IPE 100/200mm ADJUSTABLE.

WLL 1200kg with safety factor 5:1 (in combination with chain hoist).
WLL 1500kg with safety factor 4:1





GENERAL FEATURES

Model	EXE iBeam Trolley
Type	Trolley
WLL	1200kg safety factor 5:1 1500kg safety factor 4:1
Body Colour	Black / Silver
HEA/IPE	100/200mm ADJUSTABLE

IPE

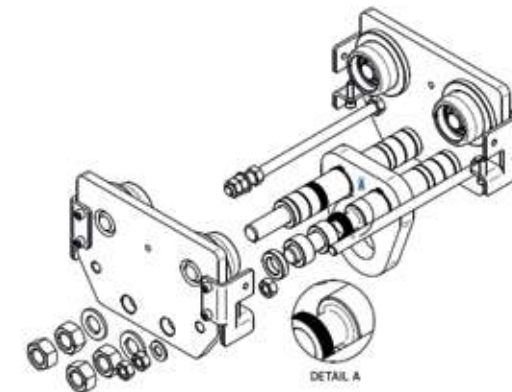
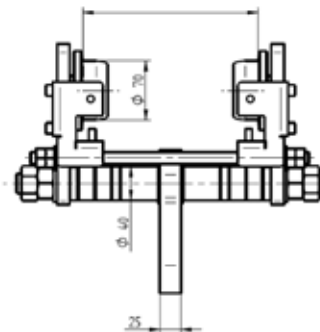
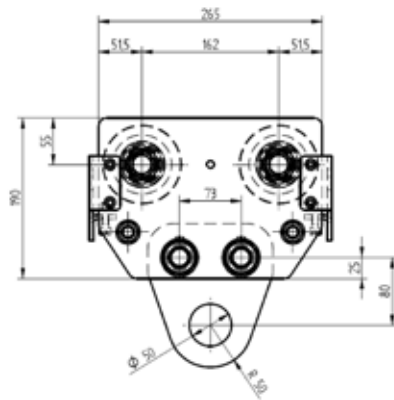
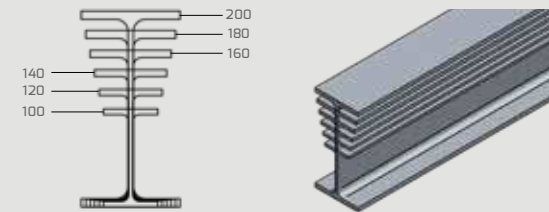

EXE DRIVE CONTROLLER

**PRACTICAL,
SELECTABLE & WIDE RANGE**



EXE Drive controllers are classified as either Basic or Linkable. Basic units allow for simple control without the ability to group units together whereas linkable units can be connected and operated altogether at the same time, allowing you to use up to 9 EXE Drive controllers or 8 drive controllers plus one remote.

The Basic 3-phase direct or low voltage control units are available in 4 or 8 channel modules. The Linkable 3-phase direct or low voltage control units are available in 4, 8, 16, or 24 channel modules. Specialty units include the 8-channel wireless direct control unit and the single-phase 4-channel unit.







































To operate hoists connected to EXE Drive controllers, a variety of remotes, pendants, and pickles are available. For the standalone hoist there's the standard single channel or 2-channel pickle, while for the Linkable Drive series there's multichannel solutions or simple pendants with stop-go or stop-go-reverse buttons, all of which are capable of performing without voltage drop or signal interruption with an XLR cable of up to 100 meters.

Possibility to customize for any voltage, frequency, plug, and socket requirements based on the electrical standards of your country.

The number "04" in a large, white, bold, sans-serif font, positioned on an orange triangular background element.

EXE DRIVE

OVERVIEW

3-PH CONTROLLERS	CHANNELS	LINKABLE	DIRECT CONTROL	LOW VOLTAGE CONTROL	DIGITAL REMOTE CONTROL			
	1	✗			 XDRH1C-LV			
		✗	 LDDH1					
	2	✗	 LDDH2					
	4	✗	 Xddb4	 Xddb4-LV				
		✓	 Xddl4	 Xddl4-LV	 XDRHG	 XDRHGR	 XDRH4C	
		✓	 Xddc4	✗	 XDRHGC			
	6	✓	 Xddl6		 XDRHG	 XDRHGR		
	8	✗	 Xddb8	 Xddb8-LV				
		✓	 Xddl8	 Xddl8-LV	 XDRHG	 XDRHGR	 XDRH8C	
✓		 Xddl8-H		 XDRHG	 XDRHGR	 XDRH8C		
✗		 Xddw8	✗					
✓		 Xddc8	✗	 XDRHGC				
16	✓	 Xddl16	 Xddl16-LV	 XDRHG	 XDRHGR	 XDRH16C		
24	✓	 Xddl24	 Xddl24-LV	 XDRHG	 XDRHGR	 XDRH24C		



LDDH1

1-CHANNEL PENDANT PUSH BUTTON

KEY FEATURES

- Double-isolated yellow keypad in polyester
- 1 x Emergency Stop button
- 2 x mechanical interlock UP-DOWN switches (requires operator to be present)
- Compatible with most chain hoists available on the market

TECHNICAL SPECIFICATIONS

Power:	2.2kW
Power Supply:	1 plug CEE 230/400VAC 16A 6H 3P+N+T IP67 with mechanical phase inverter
Outputs:	1 x CEE 400VAC 16A 6H 3P+T IP67 flying plug
Rated operational current per output:	10A in AC3 – AC4
Ambient Temperature – Storage:	-25°C/+70°C
Ambient Temperature – Operation:	-25°C/+40°C
Dimensions:	200x85x75.4 mm 7.8x3.3x3.0 inch
Weight:	1,5 kg / 3.3 lbs



LDDH2

2-CHANNEL PENDANT PUSH BUTTON

KEY FEATURES

- Double-isolated yellow keypad in polyester
- 1 x Emergency Stop button
- 2 x mechanical interlock UP-DOWN switches (requires operator to be present)
- Compatible with most chain hoists available on the market

TECHNICAL SPECIFICATIONS

Power:	2.2kW
Power Supply:	1 plug CEE 230/400VAC 16A 6H 3P+N+T IP67 with mechanical phase inverter
Outputs:	2 x CEE 400VAC 16A 6H 3P+T IP67 flying plug
Rated operational current per output:	5A in AC3 - AC4
Ambient Temperature - Storage:	-25°C/+70°C
Ambient Temperature - Operation:	-25°C/+40°C
Dimensions:	310x98x76 mm 12.2x3.9x3.0 inch
Weight:	2.0 kg / 4.4 lbs

**EX3
DRIVE**

DB4

DIRECT CONTROL



XDDB4
4-CHANNEL BASIC CONTROLLER

KEY FEATURES

- 3 Neon Light for Power Supply indication
- MCB 16A & GFI Breaker (30mA)
- Emergency Stop button
- White GO button
- 4 x 3-travel direction selectors (UP-OFF-DOWN)

TECHNICAL SPECIFICATIONS

Power Supply:	1 plug CEE 230/400VAC 32A 6H 3P+N+E w/mechanical phase inverter
Outputs:	4 x CEE 400VAC 16A 6H 3P+T IP67 flying plug
Dimensions:	3U rack box 260mm depth
Weight:	12 kg / 26.5 lbs

FRONT VIEW

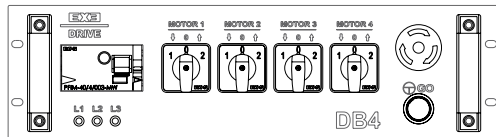

BACK VIEW

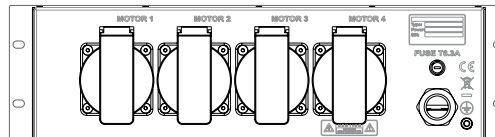



XDDB4-LV 4-CHANNEL BASIC CONTROLLER

KEY FEATURES

- 3 Red Neon Light for Power Supply indication
- MCB 16A & GFI Breaker (30mA)
- Emergency Stop button
- White GO button
- 4 x 3-travel direction selectors (UP-OFF-DOWN)
- Protection General Contactor
- Pickle Power

TECHNICAL SPECIFICATIONS

Power Supply:	230/400VAC 32A 6H 3P+N+E w/mechanical phase inverter
Outputs:	2 x 19 pin circular multi-pin female connector. Two channel power and 2 channel control per connector
Dimensions:	3U rack box 260mm depth
Weight:	12 kg / 26.5 lbs

FRONT VIEW

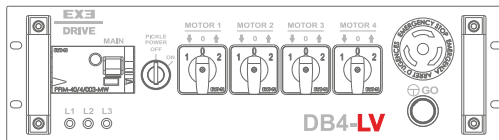

BACK VIEW

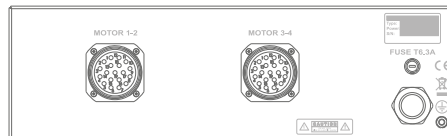

XDSP2 - LV

This adapter is used to split the Multi-pin outlets out to 16amp power and control connectors to enable connection to chain hoists.



XDDB8 8-CHANNEL BASIC CONTROLLER

KEY FEATURES

- 3 Red Neon Light for Power Supply indication
- MCB 16A & GFI Breaker (30mA)
- Emergency Stop button
- White GO button
- 8 x 3-travel direction selectors (UP-OFF-DOWN)
- Protection General Contactor

TECHNICAL SPECIFICATIONS

Power Supply:	1 plug CEE 230/400VAC 16A 6H 3 P+N+E with mechanical phase inverter
Outputs:	8 x CEE 400VAC 16A 6H 3 P+E panel sockets
Dimensions:	5U rack box 260mm depth
Weight:	17 kg / 37.5 lbs

FRONT VIEW

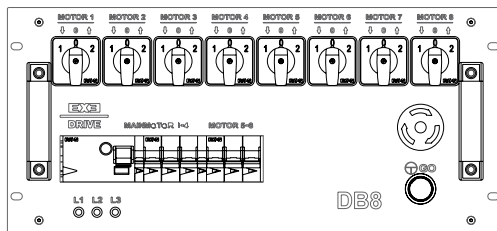

BACK VIEW

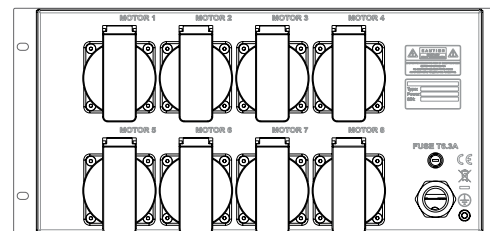

EX3 DRIVE

DB8-LV

LOW VOLTAGE CONTROL



XDDB8-LV 8-CHANNEL BASIC CONTROLLER

KEY FEATURES

- 3 Red Neon Light for Power Supply indication
- GFI 40A (30mA)
- 2 MCB 16A w/link functions between MCB and General Contactor for magneto-thermal Cut off
- Emergency Stop button
- White GO button
- 8 x 3-travel direction selectors (UP-OFF-DOWN)
- Protection General Contactor
- Pickle function

TECHNICAL SPECIFICATIONS

Power Supply:	1 plug CEE 230/400VAC 32A 6H 3 P+N+E with mechanical phase inverter
Outputs:	4 x 19 pin circular multi-pin female connector. 2 channel power and 2 channel control per connector
Dimensions:	5U rack box 260mm depth
Weight:	18.5 kg / 40.8 lbs

FRONT VIEW

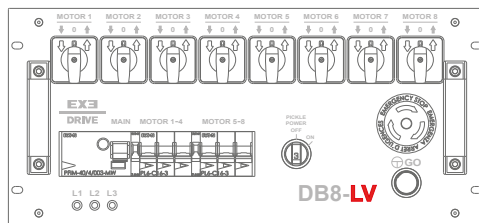

BACK VIEW

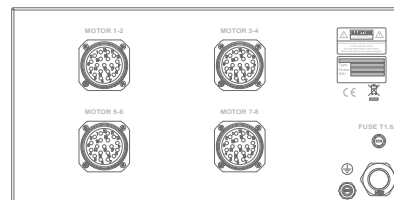

XDSP2 - LV

This adapter is used to split the Multi-pin outlets out to 16amp power and control connectors to enable connection to chain hoists.



FRONT VIEW

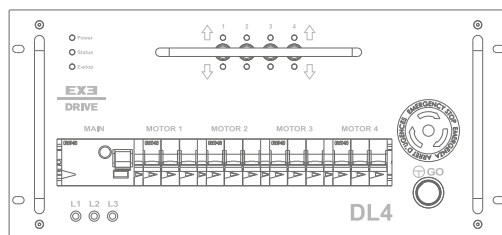

BACK VIEW

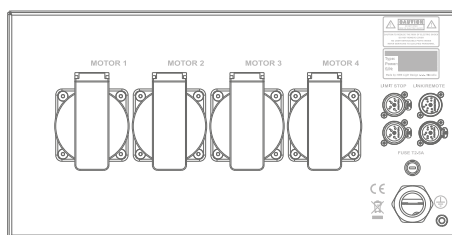

XDDL4

4-CHANNEL MULTILINK CONTROLLER

KEY FEATURES

- 3 Bicolor Led Light Green/Red for Phase Rotation indication 123 – 321
- GFI 40A (30mA)
- 4 MCB 10A w/link functions between MCB and General Contactor for magneto-thermal Cut off
- 4 x direction contactor reversal
- Emergency Stop button
- White GO button with light indication
- 4 x 3-position travel direction switches (UP-OFF-DOWN)
- 4 x green LED lights indicating channel UP preselection
- 4 x white LED lights indicating channel DOWN preselection
- XLR 5-pole OUT Link panel socket
- XLR 5-pole IN Link + REMOTE panel socket
- 2x XLR 4-pole for load cell / limit switch / E-stop
- The unit is supplied with a 1 meter link cable XLR 5-pole male/female

TECHNICAL SPECIFICATIONS

Power Supply:	1 plug CEE 230/400VAC 32A 6H 3 P+N+E with mechanical phase inverter
Outputs:	4 x CEE 400VAC 16A 6H 3 P+E panel sockets
Dimensions:	5U rack box 300mm depth
Weight:	21 kg / 46.3 lbs

EX3 DRIVE

DL4-LV

LOW VOLTAGE CONTROL

XDDL4-LV

4-CHANNEL MULTILINK CONTROLLER

KEY FEATURES

- 3 Bicolor Led Light Green/Red for Phase Rotation indication 123 - 321 GFI 40A (30mA)
- 4 MCB 10A w/link functions between MCB and General Contactor for magneto-thermal Cut off
- 4 x direction contactor reversal
- Emergency Stop mushroom button
- White GO button with light indication
- 4 x 3-position travel direction switches (UP-OFF-DOWN)
- 4 x green LED lights indicating channel UP preselection
- 4 x white LED lights indicating channel DOWN preselection
- XLR 5-pole OUT Link panel socket
- XLR 5-pole IN Link + REMOTE panel socket
- 2x XLR 4-pole for load cell / limit switch / E-stop
- The unit is supplied with a 1 meter link cable XLR 5-pole male/female

TECHNICAL SPECIFICATIONS

Power Supply:	1 plug CEE 230/400VAC 32A 6H 3 P+N+E with mechanical phase inverter
Outputs:	2 x 19 pin circular multi-pin female connector: Two channel power and 2 channel control per connector
Dimensions:	5U rack box 300mm depth
Weight:	21 kg / 46.3 lbs



FRONT VIEW

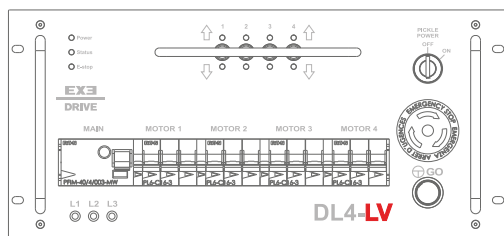

BACK VIEW

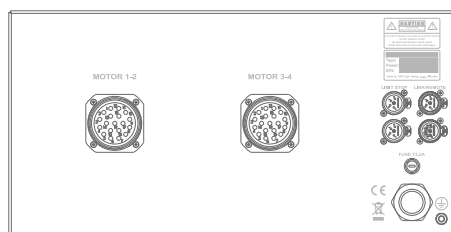

XDSP2 - LV

This adapter is used to split the Multi-pin outlets out to 16amp power and control connectors to enable connection to chain hoists.



XDDL6

6-CHANNEL MULTILINK CONTROLLER

KEY FEATURES

- 3 Bicolor Led Light Green/Red for Phase Rotation indication 123 – 321
- GFI 40A (30mA)
- 4 MCB 10A w/link functions between MCB and General Contactor for magneto-thermal Cut off
- 6 x direction contactor reversal
- Emergency Stop mushroom button
- White GO button with light indication
- 6 x 3-position travel direction switches (UP-OFF-DOWN)
- 6 x green LED lights indicating channel UP preselection
- 6 x white LED lights indicating channel DOWN preselection
- XLR 5-pole OUT Link panel socket
- XLR 5-pole IN Link + REMOTE panel socket
- 2x XLR 4-pole for load cell / limit switch / E-stop
- The unit is supplied with a 1 meter link cable XLR 5-pole male/female

TECHNICAL SPECIFICATIONS

Power Supply:	1 plug CEE 230/400VAC 32A 6H 3 P+N+E with mechanical phase inverter
Outputs:	6 x CEE 400VAC 16A 6H 3 P+T panel sockets
Dimensions:	5U rack box 300mm depth
Weight:	25 kg / 55.1 lbs

FRONT VIEW

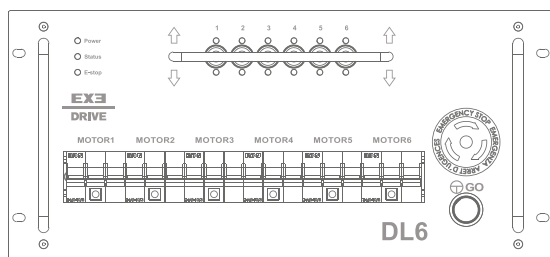

BACK VIEW

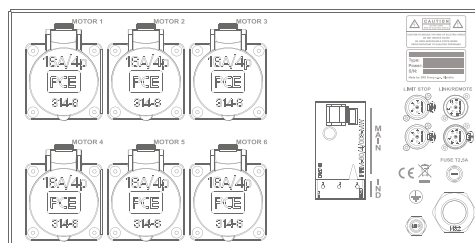



**EX3
DRIVE**

DL8

DIRECT CONTROL



FRONT VIEW

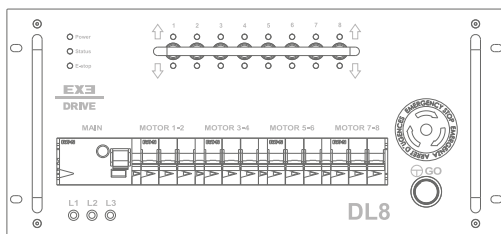

BACK VIEW

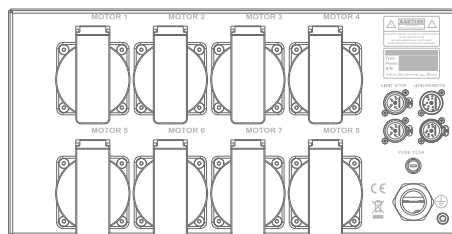

XDDL8

8-CHANNEL MULTILINK CONTROLLER

KEY FEATURES

- 3 Bicolor Led Light Green/Red for Phase Rotation indication 123 – 321
- GFI 40A (30mA)
- 4 MCB 10A w/link functions between MCB and General Contactor for magneto-thermal Cut off
- 8 x direction contactor reversal
- Emergency Stop mushroom button
- White GO button with light indication
- 8 x 3-position travel direction switches (UP-OFF-DOWN)
- 8 x green LED lights indicating channel UP preselection
- 8 x white LED lights indicating channel DOWN preselection
- XLR 5-pole OUT Link panel socket
- XLR 5-pole IN Link + REMOTE panel socket
- 2x XLR 4-pole for load cell / limit switch / E-stop
- The unit is supplied with a 1 meter link cable XLR 5-pole male/female

TECHNICAL SPECIFICATIONS

Power Supply:	1 plug CEE 230/400VAC 32A 6H 3 P+N+E with mechanical phase inverter
Outputs:	8 x CEE 400VAC 16A 6H 3 P+T panel sockets
Dimensions:	5U rack box 300mm depth
Weight:	25 kg / 55.1 lbs

EX3 DRIVE

DL8-LV

LOW VOLTAGE CONTROL



FRONT VIEW

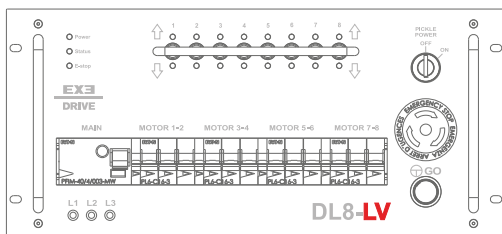

BACK VIEW

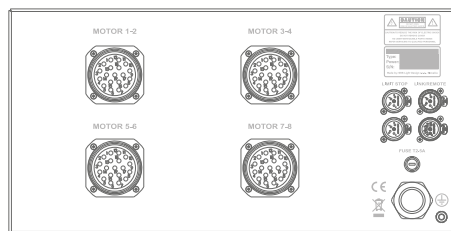

XDDL8-LV 8-CHANNEL MULTILINK CONTROLLER

KEY FEATURES

- 3 Bicolor Led Light Green/Red for Phase Rotation indication 123 – 321
- GFI 40A (30mA)
- 4 MCB 10A w/link functions between MCB and General Contactor for magneto-thermal Cut off
- Protection General Contactor
- 8 x direction contactor reversal
- Emergency Stop mushroom button
- White GO button (requires operator to be present) with light indication
- 8 x 3-position travel direction switches (UP-OFF-DOWN)
- 8 x green LED lights indicating channel UP preselection
- 8 x white LED lights indicating channel DOWN preselection
- XLR 5-pole OUT Link panel socket
- XLR 5-pole IN Link + REMOTE panel socket
- 2x XLR 4-pole for load cell / limit switch / E-stop
- The unit is supplied with a 1 meter link cable XLR 5-pole male/female

TECHNICAL SPECIFICATIONS

Power Supply:	1 plug CEE 230/400VAC 32A 6H 3 P+N+E with mechanical phase inverter
Outputs:	2 x 19 pin circular multi-pin female connector. Two channel power and 2 channel control per connector
Dimensions:	5U rack box 300mm depth
Weight:	21 kg / 46.3 lbs



XDSP2 - LV

This adapter is used to split the Multi-pin outlets out to 16amp power and control connectors to enable connection to chain hoists.

**EX3
DRIVE**

DL8H

DIRECT CONTROL



FRONT VIEW

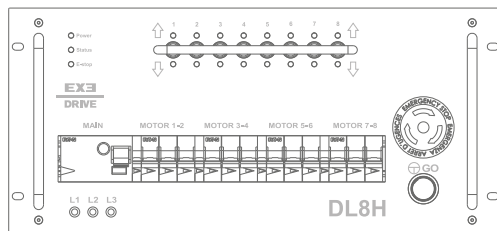

BACK VIEW

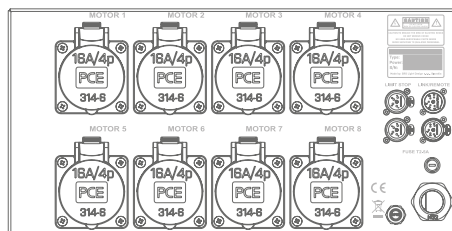

XDDL8H

8-CHANNEL HIGH MULTILINK CONTROLLER

KEY FEATURES

- 3 Bicolor Led Light Green/Red for Phase Rotation indication 123 – 321
- GFI 40A (30mA)
- 4 MCB 10A w/link functions between MCB and General Contactor for magneto-thermal Cut off
- 8 x direction contactor reversal
- Emergency Stop mushroom button
- White GO button with light indication
- 8 x 3-position travel direction switches (UP-OFF-DOWN)
- 8 x green LED lights indicating channel UP preselection
- 8 x white LED lights indicating channel DOWN preselection
- XLR 5-pole OUT Link panel socket
- XLR 5-pole IN Link + REMOTE panel socket
- 2x XLR 4-pole for load cell / limit switch / E-stop
- The unit is supplied with a 1 meter link cable XLR 5-pole male/female

TECHNICAL SPECIFICATIONS

Power Supply:	1 plug CEE 230/400VAC 63A6H 3 P+N+E with mechanical phase inverter
Outputs:	8 x CEE 400VAC 16A 6H 3 P+T panel sockets
Dimensions:	5U rack box 300mm depth
Weight:	27.5 kg / 60.6 lbs

EX3
DRIVE

MAIN

MOTOR 1-2

MOTOR 3-4

MOTOR 5-6

MOTOR 7-8

DL8-LV

LED

L1 L2 L3

L1 L2 L3

EMERGENCY STOP
OFF

ON

GO





FRONT VIEW

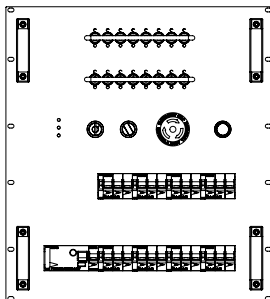

BACK VIEW

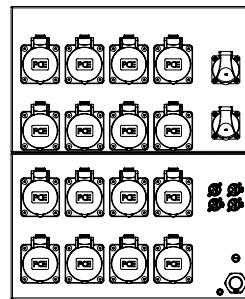

XDDL16

16-CHANNEL MULTILINK CONTROLLER

KEY FEATURES

- 3 Bicolor Led Light Green/Red for Phase Rotation indication 123 – 321
- GFI 40A (30mA)
- 8 MCB 10A w/link functions between MCB and General Contactor for magneto-thermal Cut off
- 16 x direction contactor reversal
- Emergency Stop mushroom button
- White GO button with light indication
- 16 x 3-position travel direction switches (UP-OFF-DOWN)
- 16 x green LED lights indicating channel UP preselection
- 16 x white LED lights indicating channel DOWN preselection
- XLR 5-pole OUT Link panel socket
- XLR 5-pole IN Link + REMOTE panel socket
- 2x XLR 4-pole for load cell / limit switch / E-stop
- The unit is supplied with a 2 meters link cable XLR 5-pole male/female

TECHNICAL SPECIFICATIONS

Power Supply:	1 plug CEE 230/400VAC 63A 6H 3 P+N+E with mechanical phase inverter
Outputs:	16 x CEE 400VAC 16A 6H 3 P+E panel socket
Dimensions:	12U rack box 300mm depth
Weight:	44 kg / 97.0 lbs



FRONT VIEW

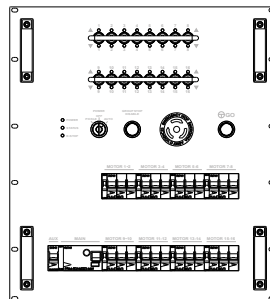

BACK VIEW

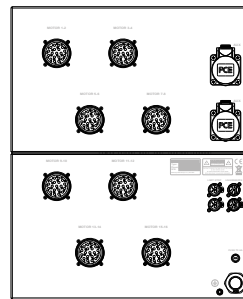

XDDL16-LV
16-CHANNEL MULTILINK CONTROLLER

KEY FEATURES

- 3 Bicolor Led Light Green/Red for Phase Rotation indication 123 – 321
- GFI 40A (30mA)
- 8 MCB 10A w/link functions between MCB and General Contactor for magneto-thermal Cut off
- 16 x direction contactor reversal
- Emergency Stop mushroom button
- White GO button with light indication
- 16 x 3-position travel direction switches (UP-OFF-DOWN)
- 16 x green LED lights indicating channel UP preselection
- 16 x white LED lights indicating channel DOWN preselection
- XLR 5-pole OUT Link panel socket
- XLR 5-pole IN Link + REMOTE panel socket
- 2x XLR 4-pole for load cell / limit switch / E-stop
- The unit is supplied with a 2 meters link cable XLR 5-pole male/female
- Pickle function

TECHNICAL SPECIFICATIONS

Power Supply:	1 plug CEE 230/400VAC 63A 6H 3 P+N+E with mechanical phase inverter
Outputs:	8 x 19 pin circular multi-pin female connector. Two channel power and 2 channel control per connector
Dimensions:	12U rack box 300mm depth
Weight:	44 kg / 97.0 lbs



XDSP2-LV

This adapter is used to split the Multi-pin outlets out to 16amp power and control connectors to enable connection to chain hoists.



FRONT VIEW

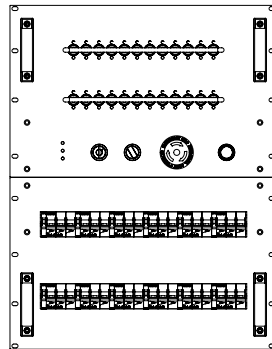

BACK VIEW

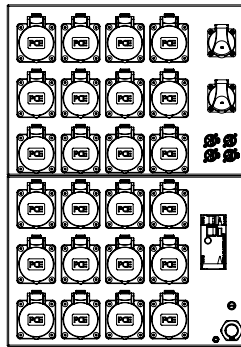

XDDL24

24-CHANNEL MULTILINK CONTROLLER

KEY FEATURES

- 3 Bicolor Led Light Green/Red for Phase Rotation indication 123 – 321
- GFI 40A (30mA)
- 12 MCB 10A w/link functions between MCB and General Contactor for magneto-thermal Cut off
- 24 x direction contactor reversal
- Emergency Stop mushroom button
- White GO button with light indication
- 24 x 3-position travel direction switches (UP-OFF-DOWN)
- 24 x green LED lights indicating channel UP preselection
- 24 x white LED lights indicating channel DOWN preselection
- XLR 5-pole OUT Link panel socket
- XLR 5-pole IN Link + REMOTE panel socket
- 2x XLR 4-pole for load cell / limit switch / E-stop
- The unit is supplied with a 2 meters link cable XLR 5-pole male/female

TECHNICAL SPECIFICATIONS

Power Supply:	1 plug CEE 230/400VAC 63A 6H 3 P+N+E with mechanical phase inverter
Outputs:	24 x CEE 400VAC 16A 6H 3 P+E panel sockets
Dimensions:	14U rack box 300mm depth
Weight:	47 kg / 103.6 lbs



FRONT VIEW

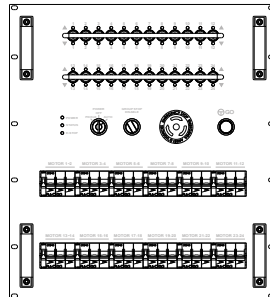

BACK VIEW

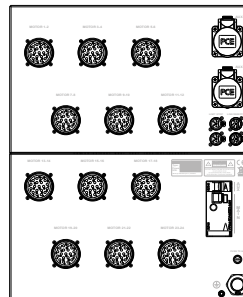

XDDL24-LV 24-CHANNEL MULTILINK CONTROLLER

KEY FEATURES

- 3 Bicolor Led Light Green/Red for Phase Rotation indication 123 – 321
- GFI 40A (30mA)
- 12 MCB 10A w/link functions between MCB and General Contactor for magneto-thermal Cut off
- 24 x direction contactor reversal
- Emergency Stop mushroom button
- White GO button with light indication
- 24 x 3-position travel direction switches (UP-OFF-DOWN)
- 24 x green LED lights indicating channel UP preselection
- 24 x white LED lights indicating channel DOWN preselection
- XLR 5-pole OUT Link panel socket
- XLR 5-pole IN Link + REMOTE panel socket
- 2x XLR 4-pole for load cell / limit switch / E-stop
- The unit is supplied with a 2 meters link cable XLR 5-pole male/female
- Pickle function

TECHNICAL SPECIFICATIONS

Power Supply:	1 plug CEE 230/400VAC 63A 6H 3 P+N+E with mechanical phase inverter
Outputs:	12 x 19 pin circular multi-pin female connector. Two channel power and 2 channel control per connector
Dimensions:	12U rack box 300mm depth
Weight:	47 kg / 103.6 lbs



XDSP2 - LV

This adapter is used to split the Multi-pin outlets out to 16amp power and control connectors to enable connection to chain hoists.

EX3 DRIVE

DW8

WIRELESS CONTROLLER



Operable only in combination with the DL8 motor controller

FRONT VIEW

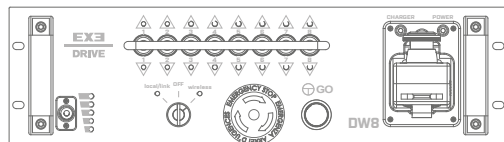

BACK VIEW



XDDW8

8-CHANNEL WIRELESS CONTROLLER

KEY FEATURES

2.4GHz working frequency with dual encryption

Switches with UP/STAY/DOWN function

GO and Emergency STOP button

Dry contacts on outputs

Power Supply: AC230V / 50Hz / 16A

Dimensions: 3U 19" box

Weight: 12.5 kg

BASE UNIT

Wireless receiver

Function key switch with OFF/LOCAL/WIRELESS control modes

Charger and storage for the REMOTE unit

LED indication for GO button, wireless signal presence, charger status

REMOTE UNIT

Wireless transmitter

Integrated antenna inside the body

Standard Motorola Li-Ion battery

Battery status indication LED

Beeper alarm function

Device status LED

Metal belt clip



Power



Status



E-stop

EX3

DRIVE

MAIN



FRONT VIEW

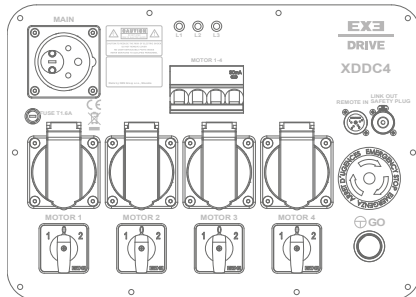

XDDC4 4-CHANNEL SUITCASE CONTROLLER

KEY FEATURES

- Controls up to 4 direct voltage hoists
- Manual Phase Align (MPA) using power input connector
- Link connector
- Housing in robust plastic case
- Emergency Stop button
- White GO button
- Magneto-thermal Cut off
- 4 x 3-cam changeover switch (UP-OFF-DOWN)
- Protection General Contactor

TECHNICAL SPECIFICATIONS

Power Supply:	CEE 32/5p
Outputs:	RCBO C16A/30mA
Dimensions:	340 x 424 x 173 mm
Weight:	8 kg



FRONT VIEW

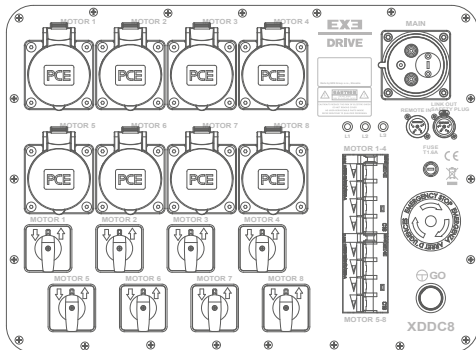

XDDC8 8-CHANNEL SUITCASE CONTROLLER

KEY FEATURES

- Controls up to 8 direct voltage hoists
- Manual Phase Align (MPA) using power input connector
- Link connector
- Housing in robust plastic case
- Emergency Stop button
- White GO button
- Magneto-thermal Cut off
- 8 x 3-cam changeover switch (UP-OFF-DOWN)
- Protection General Contactor

TECHNICAL SPECIFICATIONS

Power Supply:	CEE 32/5p
Outputs:	RCBO C16A/30mA
Dimensions:	406 x 503 x 193mm
Weight:	11.5 kg

EX3 DRIVE

DC4-SP

SUITCASE CONTROLLER



FRONT VIEW

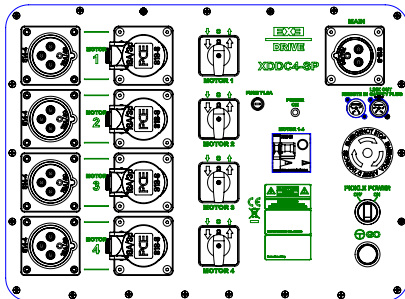

XDDC4-SP

4-CHANNEL SUITCASE CONTROLLER SINGLE PHASE

KEY FEATURES

- Controls up to 4 direct voltage hoists
- Manual Phase Align (MPA) using power input connector
- Link connector
- Housing in robust plastic case
- Emergency Stop button
- White GO button
- Magneto-thermal Cut off
- 4 x 3-cam changeover switch (UP-OFF-DOWN)
- Protection General Contactor

TECHNICAL SPECIFICATIONS

Power Supply:	CEE 16/3p
Outputs:	RCBO C16A/30mA
Outputs:	CEE16/3p MALE + FEMALE
Dimensions:	40 x 424 x 173 mm
Weight:	8-8.75 kg





XDRHG

REMOTE EMERGENCY BUTTON STOP/GO

KEY FEATURES

Yellow double-isolated pendant push button in self-extinguishing thermoplastic material, applied only to XRL 5-pole OUT Link panel plug provided with the DL controllers

1 x Red Stop button

1 x White flashing LED to enable Go function from remote control

1 x Green Go button

Cable length: 15m

1 x XLR 5-pole socket connector

XDRHGR

REMOTE EMERGENCY BUTTON STOP/GO/REVERSE

KEY FEATURES

All above features

1 x White button for Reverse function



XDRHGC
CABLE REMOTE WITH GO
AND E-STOP BUTTONS

KEY FEATURES

- Simple remote for XDDC series EXE Drive controllers
- Compatible only with Briefcase Controller DC (4-8 channels)
- GO and E-STOP buttons
- Cable length according to client's needs
- 4-pin NEUTRIK male connector

TECHNICAL SPECIFICATIONS

Size:	264 x 66 x 75mm
Weight:	0,87 kg



XDRH4C
DIGITAL REMOTE CONTROL
4 CHANNELS

KEY FEATURES

Material:	Sturdy 2mm thick aluminium box, grey powder coated pendant push button
Dimensions:	22.5x10.6x9.5 cm 8.9x4.2x3.7 inch
Weight:	0.9 kg / 2.0 lbs

- 1 x Stop mushroom button
- White GO button with light indication
- 4 x Direction switch with light indication
- 4 Bicolor Green/White LED lights indicating channel UP / DOWN preselection
- Bicolor Green/Orange LED
- Cable XLR5 male-female to be ordered separately



XDRH8C
DIGITAL REMOTE CONTROL
8 CHANNELS

KEY FEATURES

Material:	Sturdy 2mm thick aluminium box, grey powder coated pendant push button
Dimensions:	29.0x10.6x9.5 cm 11.4x4.2x3.7 inch
Weight:	1.2 kg / 2.6 lbs

- 1 x Stop mushroom button
- White GO button with light indication
- 8 x Direction switch with light indication
- 8 Bicolor Green/White LED lights indicating channel UP / DOWN preselection
- Bicolor Green/Orange LED
- Cable XLR5 male-female to be ordered separately

EX3
DRIVE

RH16C

DIGITAL REMOTE CONTROL



XDRH16C
DIGITAL REMOTE CONTROL
16 CHANNELS

KEY FEATURES

Material:	Sturdy 2mm thick aluminium box, grey powder coated pendant push button
Dimensions:	29.5x20.0x9.5 cm 11.6x7.9x3.7 inch
Weight:	1.8 kg / 4.0 lbs
1 x Stop mushroom button	
White GO button with light indication	
16 x Direction switch with light indication	
16 Bicolor Green/White LED lights	
indicating channel UP / DOWN preselection	
Bicolor Green/Orange LED	
Cable XLR5 male-female to be ordered separately	



XDRH24C
DIGITAL REMOTE CONTROL
24 CHANNELS

KEY FEATURES

Material:	Sturdy 2mm thick aluminium box, grey powder coated pendant push button
Dimensions:	36.5x20.0x9.5 cm 14.4x7.9x3.7 inch
Weight:	2.3 kg / 5.1
lbs1 x Stop mushroom button	
White GO button with light indication	
24 x Direction switch with light indication	
24 Bicolor Green/White LED lights indicating channel UP / DOWN preselection	
Bicolor Green/Orange LED	
Cable XLR5 male-female to be ordered separately	

EX3
DRIVE

SP2-LV
RH1C-LV

LOW VOLTAGE CONTROL



XDSP2-LV
SPIDER
BREAK-OUT ADAPTER MULTI-PIN

KEY FEATURES

This adapter is required to split the 19 male pin Multi-pin outlets out to 16A CEE connectors to enable connection to chain hoists.

19 Pin circular multi-pin male connector
4 x 100cm long legs wired on 4G 1.5m/sq HO7 RNF cable
CEE 16A 6h 400VAC - 3PH + G red socket
CEE 16A 4h 24VAC - 3PH + G yellow plug



XDRH1C-LV
1-CHANNEL PICKLE
UP-DOWN

















KEY FEATURES

Double insulated enclosures in thermoplastic self-extinguishing material
P65 rating
Operating temperature -25° +70°C
2 directions mechanically interlocked: UP & DOWN

CHAIN HOIST AND CONTROLLER COMPATIBILITY

EXE DRIVE

COMPATIBILITY CHART

EXE DRIVE MOTOR CONTROLLER		EXE RISE CHAIN HOIST CONTROLLER ■ D8+					
		250kg	500kg	1000kg	2000kg 2 REEVES	1600kg	2000kg 1 REEVES
 XDRH1C-LV		✓	✓	✓	✓	✓	✓
 LDDH1	 LDDH2	✓	✓	✓	✓/✗	✓/✗	✗
 XDDL4	 XDDL4-LV	✓	✓	✓	✓	✓	✓
 XDDL6		✓	✓	✓	✓	✓	✓
 XDDL8	 XDDL8-LV	✓	✓	✓	✗	✗	✗
 XDDL8H		✓	✓	✓	✓	✓	✓
 XDDL16	 XDDL16-LV	✓	✓	✓	✗	✗	✗
 XDDL24	 XDDL24-LV	✓	✓	✓	✗	✗	✗
 XDBB4	 XDBB4-LV	✓	✓	✓	✗	✗	✗
 XDBB8	 XDBB8-LV	✓	✓	✓	✗	✗	✗
 XDDC4		✓	✓	✓	✗	✗	✗
 XDDC8		✓	✓	✓	✗	✗	✗

The values in the table refer to the standard EXE Drive Motor Controller.

On request, the EXE Drive Motor Controllers can be customized. Contact our technical office for more information.

05



EXE SENSE CONTROLLER

INTUITIVE,
TOUCH & QUICK



Precision at your fingertips. Control EXE Rise hoists through the digital touchscreen of the EXE Sense, the latest linkable hoist controller by EXE Technology. Command up to 64 hoists individually or in groupings by connecting linkable 8-channel EXE Sense units.

Use the touchscreen to either manually jog hoists into position or input the exact target. Alternatively, control hoists with the multi-channel touchscreen remote.

This international, one-for-all solution is available for either 208 or 400 Volt power, depending on which configuration you require for saving events in your country. The system reliably communicates with any fixed speed hoists over distances up to 15 meters through XLR10 cable.

EXE SENSE

OVERVIEW



FEATURES

8 CHANNELS

 LINKABLE

 TOUCH SCREEN

 GROUP CONTROL

 FIXED SPEED



REMOTE CONTROL

COMPATIBLE CHAIN HOISTS EXE RISE ■ D8+



250kg



500kg



1000kg



2000kg*
DOUBLE REEVE



1600kg*



2000kg*

*High version - designed on request



FRONT VIEW

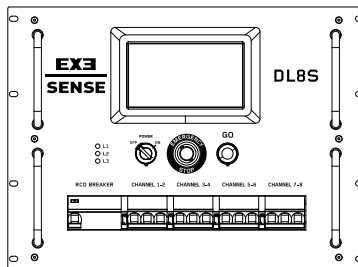

BACK VIEW

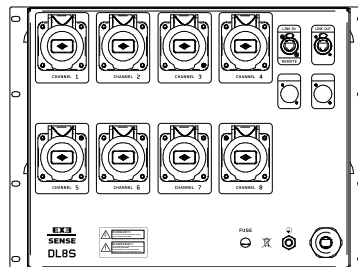

XNDL8S

8 CHANNEL MULTILINK TOUCHSCREEN CONTROLLER

KEY FEATURES

LED Touch multi-color display

GFI 40A (30mA)

4 MCB 10A w/link functions between MCB and general contactor for magneto-thermal Cut off

8 x reversing contactor

Emergency Stop mushroom button

White GO button

Ethercon Link Out

Ethercon Link In

Fuse 2A.

TECHNICAL SPECIFICATIONS

Power Supply:

1 plug CEE 230/400VAC
32A 6H 3 P+N+E

Outputs:

8 x CEE 400VAC 16A
6H 3 P+T panel sockets

Dimensions:

8U rack box 300mm depth

Weight:

40 kg / 88.2 lbs

EXE SENSE DISPLAY

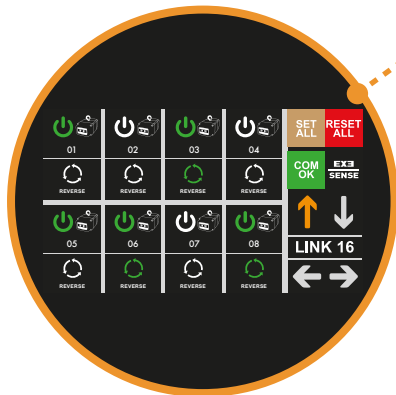
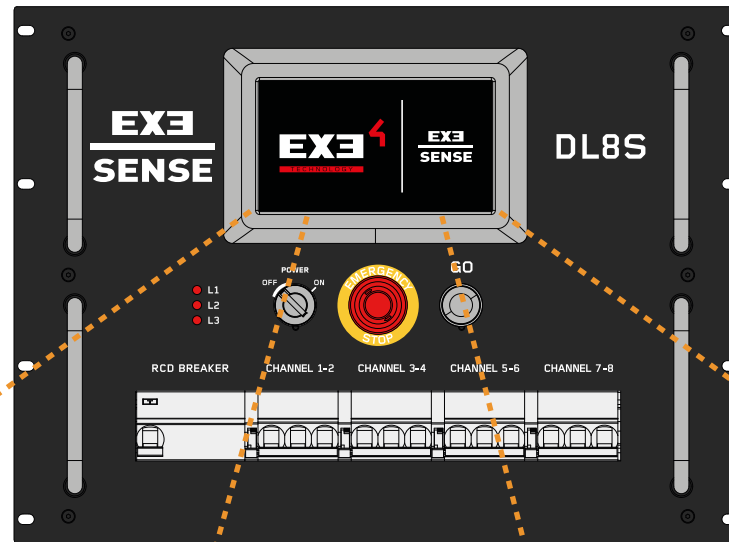

MAIN SCREEN
DISPLAY



SETTING SCREEN
DISPLAY

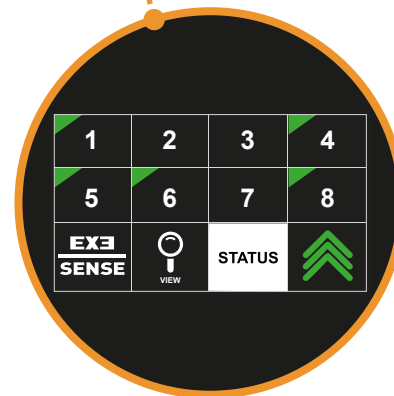

MAIN GROUP
SCREEN DISPLAY

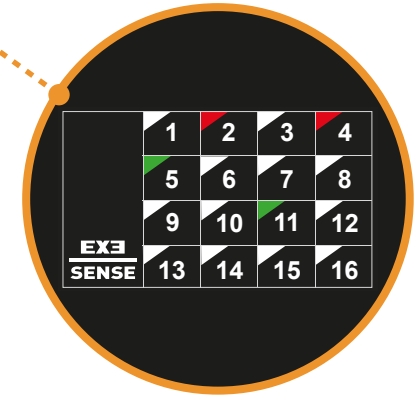

GROUP SCREEN
DISPLAY



XNDLRH
REMOTE HANDLE
TOUCH SCREEN CONTROL

KEY FEATURES

LED Touchscreen Display

LED Multi-Color Display

Emergency Stop mushroom button

White GO button

Connector RJ45.

The unit is supplied with maximum 15 meter link cable connector.

TECHNICAL SPECIFICATIONS

Outputs: Connector RJ45

Weight: 5 kg / 11 lbs



Red emergency stop button with a yellow base.

GO

01	02	03	04	SET ALL	RESET ALL
REVERSE	REVERSE	REVERSE	REVERSE	COM OK	
05	06	07	08	↑	↓
REVERSE	REVERSE	REVERSE	REVERSE	LINK 08	
				←	→

EX3
SENSE

LOAD CELL

MONITORING + AND CONTROLLING LOAD

EXE Cell is a system developed to add the over and under load safety function to the machine by monitoring and controlling the load in real time, equipped with an intelligent and intuitive software.

EXE CELL LC-PRO

+

Winner Awards for Innovation of PLASA2015, is a fully integrated in the EXE Rise chain hoists. Embedded load cell components within the body hook allows for true zero loss of headroom. The real-time load is also viewable on a color multifunction display, protected by a durable polycarbonate screen.

EXE CELL LC-NLP

+

EXE Cell LC-NLP configuration is a standalone system capable of detecting and monitor accurate weight measurements using shackles, adaptable to any applications: LED wall, ceilings, trusses, big support, etc. Lightweight solution to transport, quick to install and capable of lifting weights up to 7.5 tons.

EXE CELL LC-HKT

+

The EXE Cell LC-HKT interface uses a wireless module as an alternative to wired systems. All information is available in real-time on intuitive user interfaces on PC.

The sampling of load data is every second, with transmission varying from one second to 10 minutes depending on whether the load is variable or stable within certain values set by user.

**06**

LC-PRO
CONFIGURATION



OR



OR

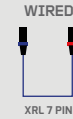
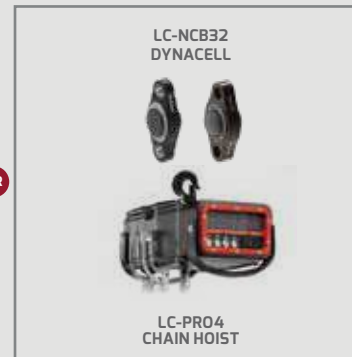

LC-NCB32
CELL BOOSTER



LC-PRO Software

LC-NLP
CONFIGURATION

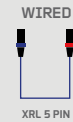

LC-NLP16
NETWORK LOAD PROCESSOR



LC-NLP SOFTWARE

LC - HKT
CONFIGURATION



WIRELESS
GATEWAY



LC-HKT SOFTWARE

EX3 CELL

LC-PRO

COMPONENTS



LC-H2T



LC-PRO4

LC-NCB32 DYNACELL



500kg



5000kg

LC-H2T CELL HOOK

KEY FEATURES

Load cell fully integrated into the hook plate assembly.
Solid and robust – Built to withstand the rigours of touring.
Easy to upgrade from a standard hook. Simply fixed in place using two bolts.
Cable from load cell to display is routed inside the hoist for additional durability.
No loss of headroom compared with external load cell systems.



LC-PRO4 CELL DISPLAY

KEY FEATURES

Calibration of loadcell via link connectors for easy setup without dismantling the hoist.
Two panel display, one to show 4-DIGIT weight (132 x 47 mm) and a second 2-DIGIT display (45 x 39 mm) has the possibility to select between pounds or kilograms. Both displays are mounted behind a durable polycarbonate protection screen.
Dual Color Multifunction display to show system calibration set up and real time weight loading, with adjustable brightness and auto power off functions.
Automatic display reverse option to provide easy to read, clear display in either body up or body down operation. Backup power supply via battery.
Optional available a Li-Ion battery to mount inside the CELL DISPLAY that is able to power the load cell without using any external power supply via link cable connector, for more details please read the instruction manual.
"Zero" value setting (Tare) function, shows the weight of the suspended load only and not the self-weight of the hoist. Double load /sleeve block/ reading setting. Setting over and under-load.

LC-NCB32 DYNACELL

KEY FEATURES

EXE LC-NCB32 is a new super-stylish ergonomic design is available in two models, 500kg & 5000kg, with perfect repeatability and reliability guarantee.
One component for a limitless range of applications. Precision, hardened eyes enable virtually any type of rigging hardware to be safely connected to create a live load monitoring system.
All on-board electronics are miniaturized. Magnetic on/off switch and hermetic containment for maximum protection from dust and water.

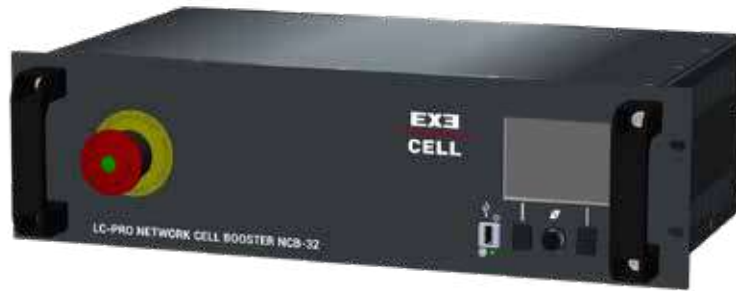

NETWORK
Input from PC /
EXE Cell Software.

LIMIT STOP OUTPUT
2 x 4pin XLR.
Hardware E-Stop
connection.

CONTROLLER DATA
1 x 5pin XLR.
(IN-OUT)

RELAY I / RELAY II
Output Max 2A.
1 x Powercon connection
external warning device

FUSE
T5A

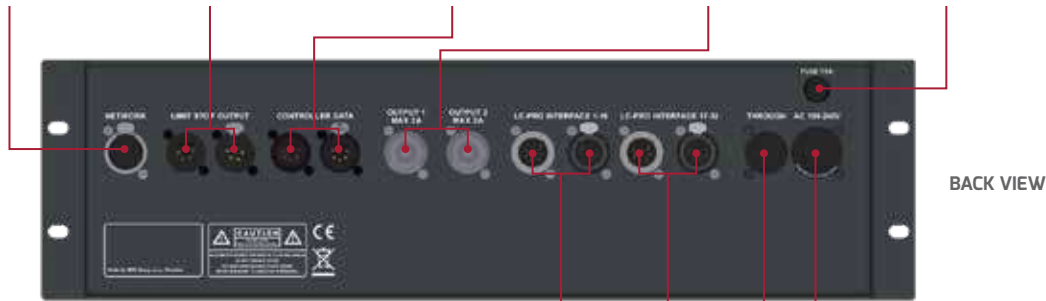

LC PRO INTERFACE 1-16
1 x 7pin XLR-M and 1 x 7pin XLR.
Power to EXE Cell.

LC PRO INTERFACE 17-32
1 x 7pin XLR-M and 1 x 7pin XLR.
Power to EXE Cell.

THROUGH
1 x Powercon.

AC 100-230V
1 x Powercon.

LC-NCB32 CELL BOOSTER

KEY FEATURES

- Powers up to 32 EXE Cell Pro Interface modules via two 7 Pin XLR output lines.
- Rack mountable – 2U.
- Front panel includes Data and Power on LED indicator lights.
- 1 x Emergency Stop mushroom button.
- Power inlet and Auxiliary out via Powercon connectors on rear (16A Max).
- Auto Sensing Voltage Selector.
- Can be connected to EXE Drive controllers and linked to activate E-stop network in case of Over/Under load.
- Multiple Boosters and EXE Drive units can be linked together.
- Max 64 channels on one network
- 2 x Powercon relay outputs on rear.
- These can be used to trigger flashing beacons or audible sounders as an additional warning in case of Over/Underload.

LC-PRO SOFTWARE



KEY FEATURES

- EXE Rise Chain Hoist Control System. EXE Cell HCapp software is free and very easy to use. It is possible to set maximum (overload) and minimum (underload) load limits for each hoist directly from the PC interface. If the load monitoring detects a hoist that reaches one of these pre-set limits the hoists will stop. In addition to this, you can also set a lesser load value than the maximum and minimum limits that will act as a visual warning that the system is approaching the pre-set cut out points.



LC-PRO SOFTWARE

CONTROLLER



5 PIN XLR male
HW E-STOP1
5 PIN XLR female

LC-NCB 32



ETHERNET CABLE
controller DATA
+ loadcell DATA

ETHERNET CABLE
controller DATA
+ loadcell DATA



ETHERNET SWITCH

ETHERNET CABLE
controller DATA
+ loadcell DATA

LC-NCB 32



5 PIN XLR female
HW E-STOP1
5 PIN XLR male

CONTROLLER

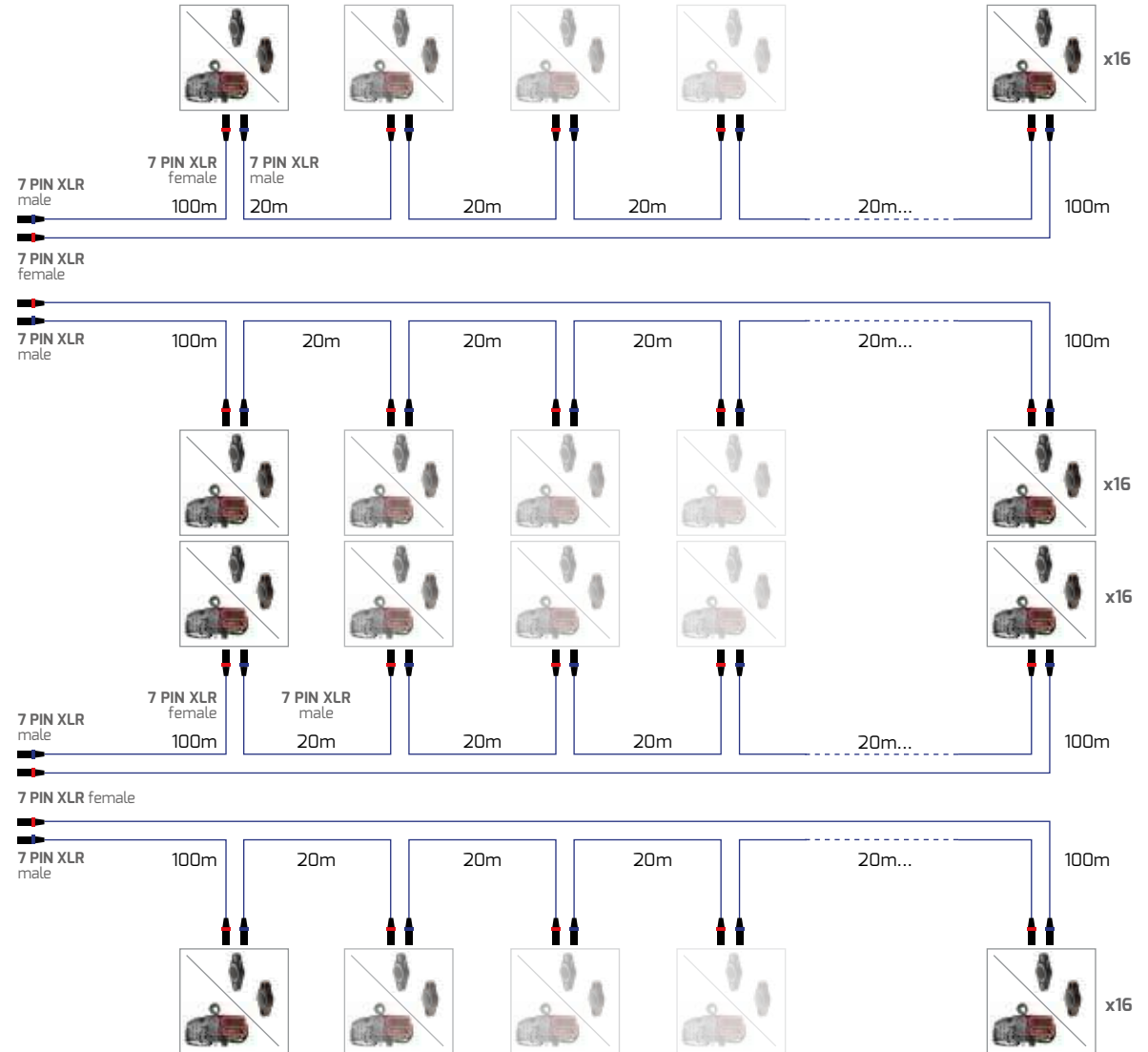

EXE CELL LC-PRO

COMPATIBILITY CHART

CHAIN HOISTS COMPATIBILITY CHART

D8+ 250kg/551lbs DC/LVC 1 REEVE	D8+ 500kg/1102lbs DC/LVC 1 REEVE	D8+ 1000kg/2205lbs DC/LVC 1 REEVE	D8+ 2000kg/4409lbs DC/LVC 2 REEVES	D8+ 1600kg/3527lbs DC/LVC 1 REEVE	D8+ 2000kg/4409lbs DC/LVC 1 REEVE	D8+ 2500kg/5512lbs DC/LVC 1 REEVE
MEDIUM FRAME COMPACT	MEDIUM FRAME	LARGE FRAME		EXTRA LARGE FRAME COMPACT	EXTRA LARGE FRAME	

EXE LC-PRO4

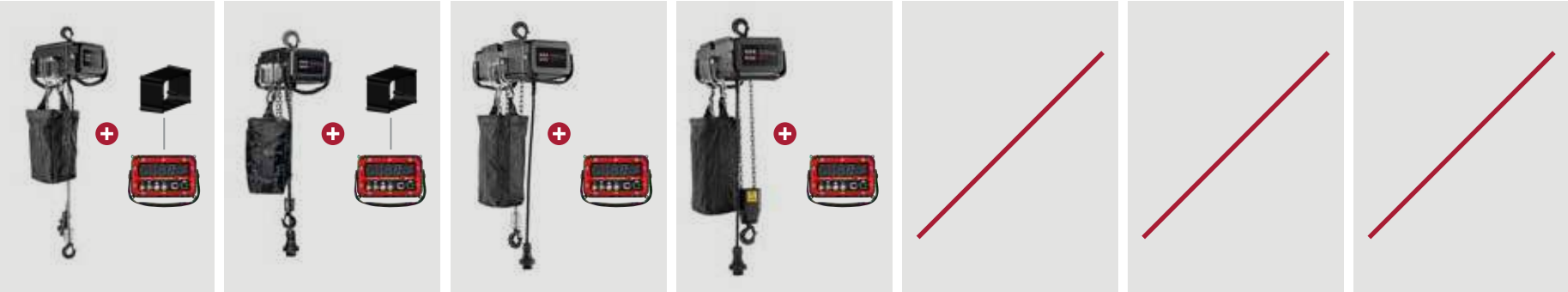

EXE LC-NCB32 DYNACELL

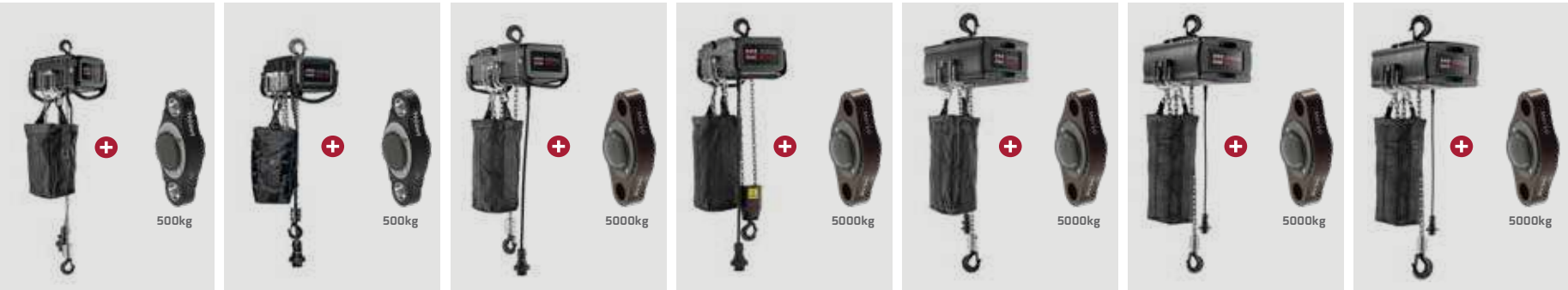

EXE DYNACELL





296kg



293.3

500kg



5000kg



LC-NLP16 **DYNACELL**

KEY FEATURES

EXE LC-NCB32 is a new super-stylish ergonomic design is available in two models, 500kg & 5000kg, with perfect repeatability and reliability guarantee.

One component for a limitless range of applications. Precision, hardened eyes enable virtually any type of rigging hardware to be safely connected to create a live load monitoring system.

All on-board electronics are miniaturized. Magnetic on/off switch and hermetic containment for maximum protection from dust and water.

LC-NLP **SOFTWARE**

KEY FEATURES

Network Loadcell Processor software is NLP Loadcell Shackle's powerful system load monitoring software.

It is highly reliable and quick and easy to use; and is supplied included in the NLP16 package.

It is possible to set both maximum (overload) and minimum (underload) load limits for each cell, plus the maximum and minimum warning levels.





LC-NLP16 NETWORK LOAD PROCESSOR

KEY FEATURES

The NLP16 is easy-to-use and user-friendly device developed by riggers. The NLP is a main unit that reads values from analog loadcell shackles with 4-20mA output and features the direct e-stop output for rigging systems. A front TFT color panel display allows the viewing of loads and groups without needing an external PC while the universal power supply allows the system to be used worldwide. The NLP can work as a fully independent part of rigging setup.

**LC-NLP16
INTERFACE 1-16**
16x5pin XLR female -20mA
input port for the loadcell
connection

**LARGE TFT FULL
COLOR DISPLAY**

**LINK A
CONTROLLER
DATA IN/OUT**
1x5pin XLR male
1x5pin XLR female

**LINK B
CONTROLLER
DATA IN/OUT**
1x5pin XLR male
1x5pin XLR female

**ETHERNET
CONNECTION**

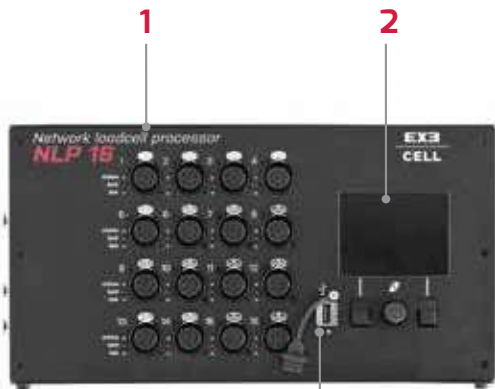

FRONT VIEW



BACK VIEW

3
USB CONNECTION

4
1xPOWERCON
Power IN

5
1xPOWERCON
Power link
through

6
E-STOP 1:
LIMIT STOP IN
1x4pin XLR male

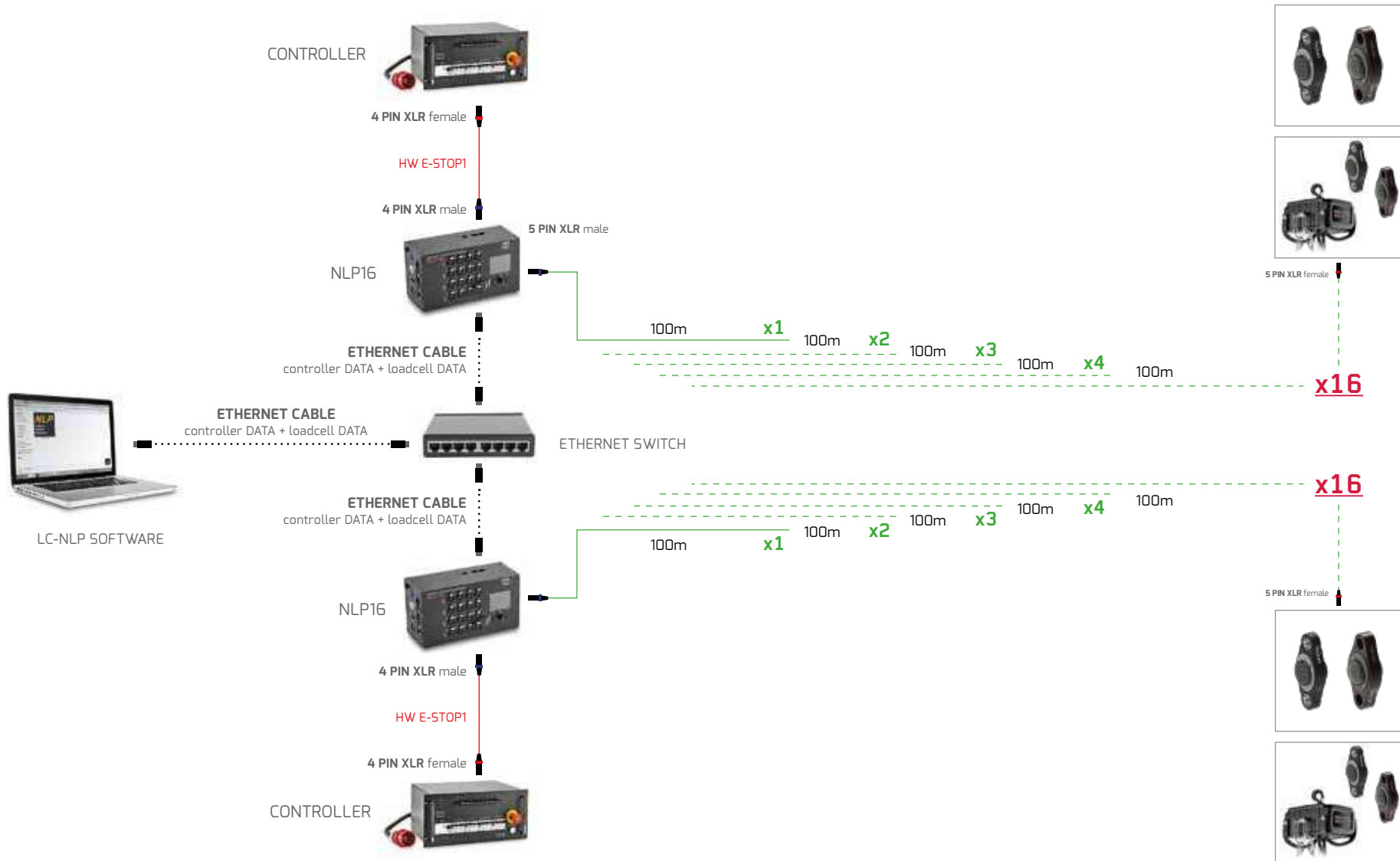



EXE CELL LC-NLP

COMPATIBILITY CHART

CHAIN HOISTS COMPATIBILITY CHART

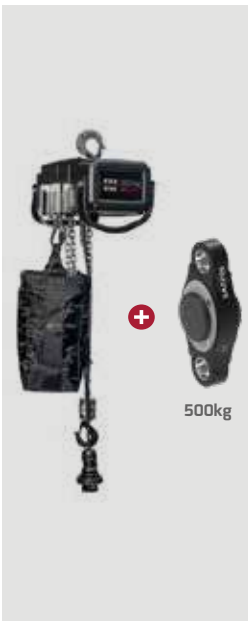
LC-NLP16 EXE DYNACELL

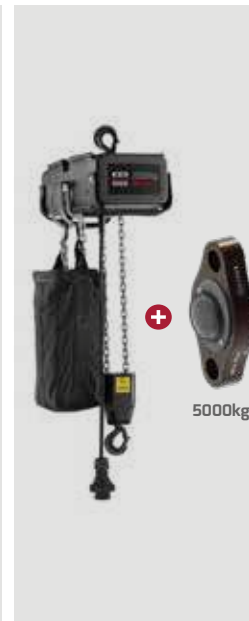
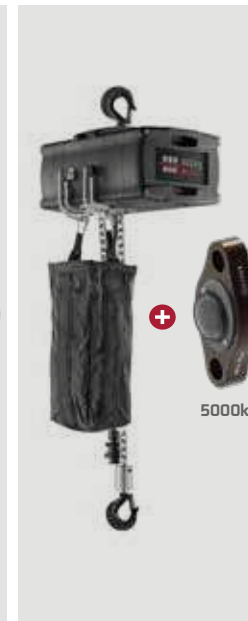
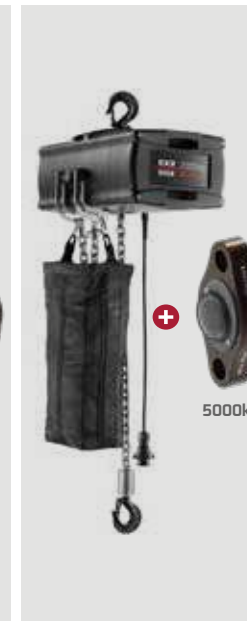
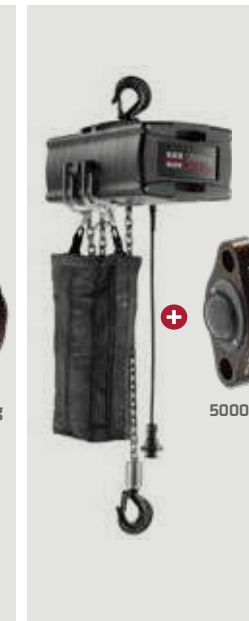
D8+ 250kg/551lbs DC/LVC 1 REEVE	D8+ 500kg/1102lbs DC/LVC 1 REEVE	D8+ 1000kg/2205lbs DC/LVC 1 REEVE	D8+ 2000kg/4409lbs DC/LVC 2 REEVES	D8+ 1600kg/3527lbs DC/LVC 1 REEVE	D8+ 2000kg/4409lbs DC/LVC 1 REEVE	D8+ 2500kg/5512lbs DC/LVC 1 REEVE
MEDIUM FRAME COMPACT	MEDIUM FRAME	LARGE FRAME		EXTRA LARGE FRAME COMPACT	EXTRA LARGE FRAME	
						

EXE DYNACELL



EX3 CELL

LC-HKT

COMPONENTS



LC-H2T CELL HOOK

KEY FEATURES

Load cell fully integrated into the hook plate assembly.
Solid and robust – Built to withstand the rigours of touring.
Easy to upgrade from a standard hook.
Simply fixed in place using two bolts.
Cable from load cell to display is routed inside the hoist for additional durability.
No loss of headroom compared with external load cell systems.



LC-HKT WIRELESS CELL PANEL

KEY FEATURES

Wireless calibration of loadcell for easy setup without dismounting the hoist.
Ultra-low profile, wall panel, robust, tamper proof design antenna.
On/Off magnetic switch under the front panel for a high IP level. (the magnetic Reed is used to switch the cell module and radio transmission on and off and is independent of the hoist power supply).
RGB LED status indicator.
The Load Cell and Radio Module are powered with four C batteries to guarantee long lasting life (till several years)
No tools are needed to access the batteries, all you need to do is unscrew the cap of the battery holders.
Battery-saving smart transmission strategy: it transmits every second when the load change exceeds a configurable threshold, transmits less often when the load is stable keep on reading every second.
The transmission automatically switches off in case of long inactivity to reduce battery consumption.

LC-HKT MAGNETIC KEY

KEY FEATURES

To ensure high IP protection, the radio module is not equipped with external mechanical switch. There is a magnetic switch which can be activated with the magnetic key. The switch is turned on or off by placing the key close to the centre of the front panel of the hoist.

EX3 CELL

LC-HKT

GATEWAY



MEDIUM FRAME/
MEDIUM FRAME COMPACT



LARGE FRAME



EXTRA LARGE FRAME/
EXTRA LARGE FRAME COMPACT



LC-HKT GATEWAY

KEY FEATURES

The gateway receives the signals from the cells and sends them to a PC for local management of the system. At the next internet access, all data are sent from the PC to the Cloud Data Storage* to be accessed by other devices. * (function not yet available)

PC connection via USB cable.

ABS enclosure.

Ultra-low profile, wall panel, robust, tamper proof design antenna.

RGB LED for Power, backup battery charge, TX and RX.

The maximum distance between hoists and the gateway is around 400 meters in line-of-sight. If longer ranges are required or large obstacles are placed in between, it is necessary to add one wireless repeater.

Fully compatible with Flexa Wireless Load Cell System.



LC-HKT SOFTWARE

KEY FEATURES

User Interfaces allow creating multiple events at the same time.

"Sectors" are created for each event, which in turn are divided into "zones."

Each zone is populated with an indefinite number of hoists, EXE Smart Pins or Flexa Shackle Wireless Load Cells.

Information is always available on the history of each hoist load cell, as well as the load graphs, battery charge values, radio signal quality and the date recommended for the next recalibration.

Each sector, zone or hoist has its own interface page that can be opened individually or simultaneously with other pages on multiple screens.

The overload and underload levels can be set by the operator.

All tables can be downloaded in PDF, CSV, EXCEL format. If cloud storage* is enabled, data can be shared, but parameters cannot be changed remotely. * (function not yet available)



LC-HKT SOFTWARE





USB CABLE



WIRELESS GATEWAY
READS UP to 100 unit

EXE CELL LC-HKT

COMPATIBILITY CHART

	D8+ 250kg/551lbs DC/LVC 1 REEVE	D8+ 500kg/1102lbs DC/LVC 1 REEVE	D8+ 1000kg/2205lbs DC/LVC 1 REEVE	D8+ 2000kg/4409lbs DC/LVC 2 REEVES	D8+ 1600kg/3527lbs DC/LVC 1 REEVE	D8+ 2000kg/4409lbs DC/LVC 1 REEVE	D8+ 2500kg/5512lbs DC/LVC 1 REEVE
	MEDIUM FRAME COMPACT	MEDIUM FRAME	LARGE FRAME		EXTRA LARGE FRAME COMPACT	EXTRA LARGE FRAME	
CHAIN HOISTS COMPATIBILITY CHART	 + 	 + 	 + 	 + 	 + 	 + 	 + 

THE WIRELESS DYNACELL LOAD CELLS PRODUCTS POWERED BY FLEXA, ARE COMPATIBLE AND COMBINABLE WITH THE EXE CELL LC-HKT

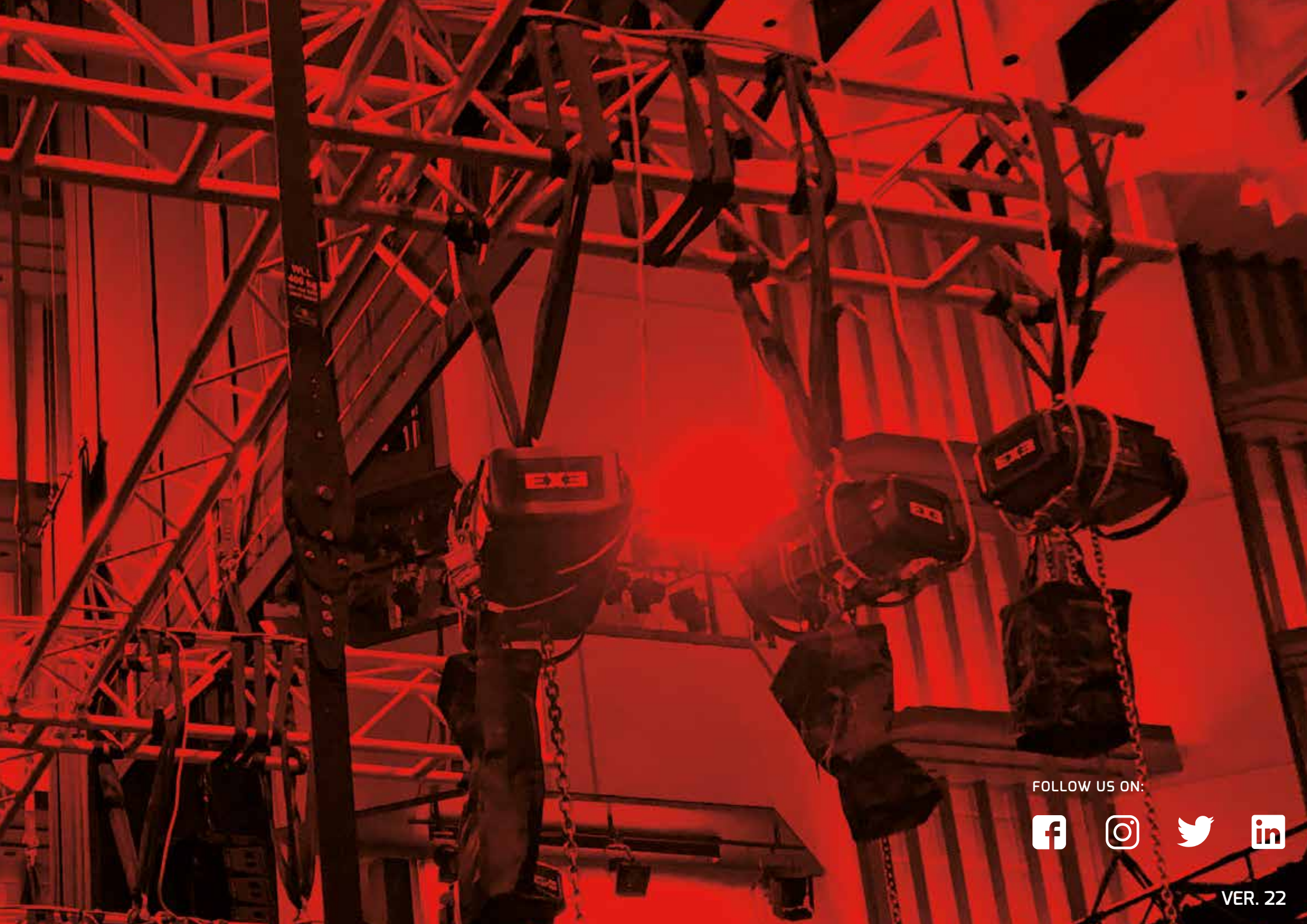

PHOTO CREDITS

AMG INTERNATIONAL S.R.L.
www.amginternational.it

THEATRE SAFE AUSTRALIA
www.theatresafe.com.au

THE.STUDIO.ROCKS



WLL
500 kg

FOLLOW US ON:



VER. 22



AREA FOUR INDUSTRIES ITALIA S.R.L

Via Martin Luther King, 70
Casale sul Sile (TV) - 31032

Tel.: +39 0422997300

Fax: +39 0422997399

info@exetechnology.com

www.exetechnology.com

